

TOLERANCES UNLESS OTHERWISE SPECIFIED

MACHINING		SHEETMETAL	
XX	0.0300	XX	± 0.0
XXX	0.0100	XXX	± 0.020
XXXX	0.0050	XXXX	NOTED
XXXXX	0.0005	XXXXX	ANGULAR 0.5°
ANGULAR	0.5°	DEBURR	ALL EDGES
DEBURR	ALL EDGES	ALL WEIGHTS	ARE IN POUNDS



Allison Park Group, Inc (APG)
4055 Alpha Drive
Allison Park, PA 15101 USA
Phone +1 (412) 487-8211
Fax +1 (412) 486-3157

THIS PRINT IS THE PROPERTY OF ALLISON PARK GROUP. THE INFORMATION CONTAINED HEREIN IS CONFIDENTIAL. IT IS NOT TRANSFERABLE. IT IS FURNISHED WITH THE CLEAR UNDERSTANDING THAT IT IS NOT TO BE TRACED, REPRODUCED OR USED IN ANY PROCESS OF MANUFACTURING WITHOUT WRITTEN PERMISSION FROM THE OWNER AND IS RETURNABLE UPON DEMAND. ANY INFRINGEMENT UPON THE PATENT RIGHTS SHOWN HEREIN, WHETHER IN PART OR WHOLE, WILL BE PROSECUTED. AS PART OF OUR POLICY OF CONTINUING DEVELOPMENT, ALLISON PARK GROUP RESERVES THE RIGHT TO ALTER SPECIFICATIONS WITHOUT PRIOR NOTICE.

DESCRIPTION: Universal Arm, 7.5" Barrel

MATERIAL: See detail drawings APPROX. WEIGHT: 1.62

DRAWN BY: M. Hart DATE: 15 Jun 17 SCALE: NTS SHT-SIZE: A REF. NUMBER: 35C-AD
CHECKED BY: DATE: PART NUMBER: REVISION: A
APPROVED BY: DATE: Sheet 1 of 1

REV.	DESCRIPTION	DATE	REV. BY	APPR. BY
REVISIONS				

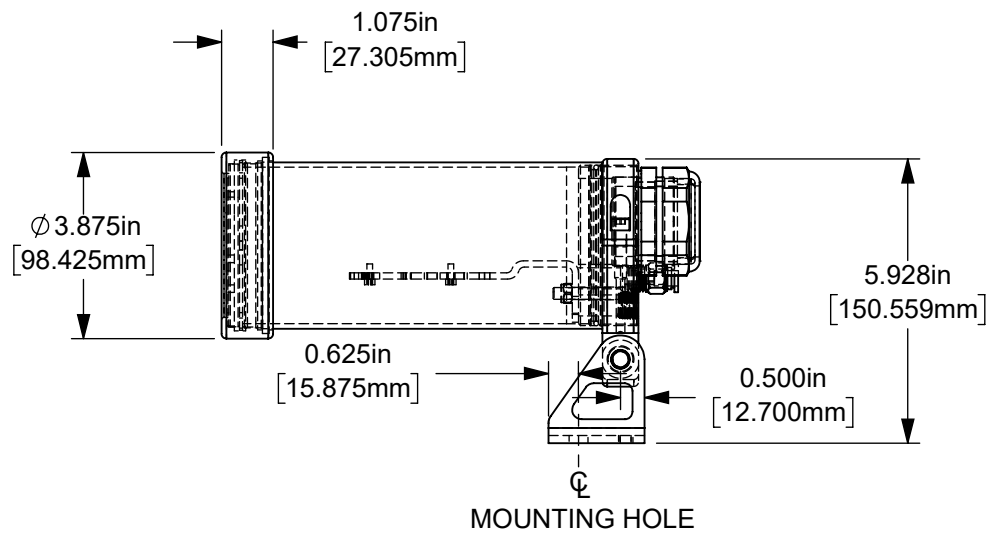
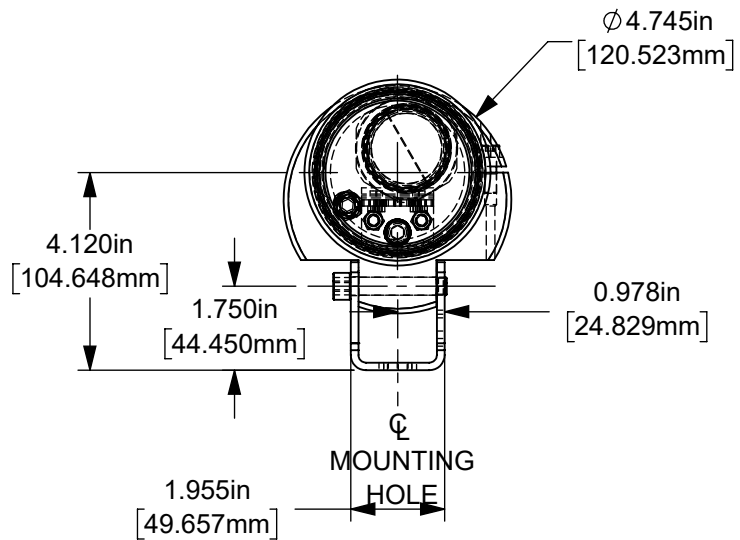
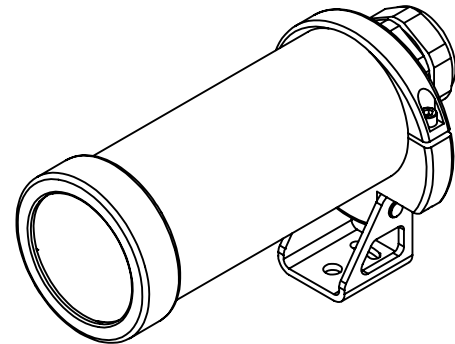
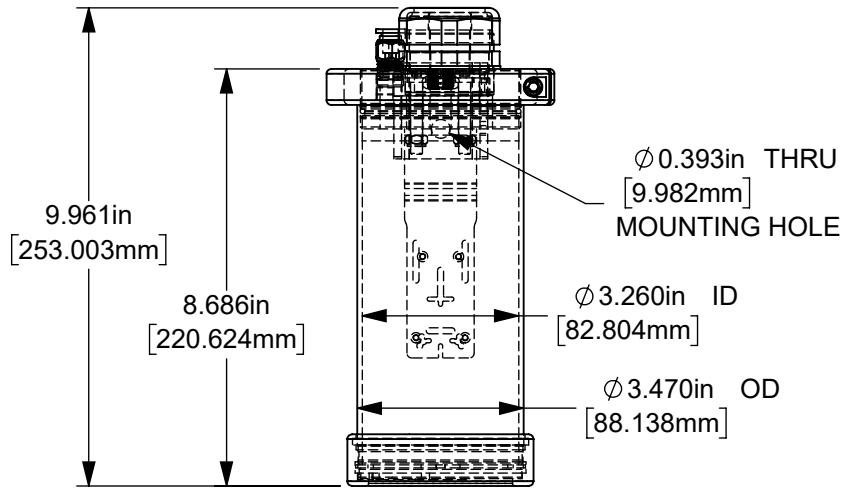

TOLERANCES UNLESS OTHERWISE SPECIFIED

MACHINING		SHEETMETAL	
XX	0.0300	XX	± 0.0
XXX	0.0100	XXX	± 0.020
XXXX	0.0050	XXXX	NOTED
XXXXX	0.0005	XXXXX	ANGULAR 0.5°
ANGULAR	0.5°	DEBURR	ALL EDGES
DEBURR	ALL EDGES		

ALL WEIGHTS ARE IN POUNDS



Allison Park Group, Inc (APG)
 4055 Alpha Drive
 Allison Park, PA 15101 USA
 Phone +1 (412) 487-8211
 Fax +1 (412) 486-3157

THIS PRINT IS THE PROPERTY OF ALLISON PARK GROUP. THE INFORMATION CONTAINED HEREIN IS CONFIDENTIAL. IT IS NOT TRANSFERABLE. IT IS FURNISHED WITH THE CLEAR UNDERSTANDING THAT IT IS NOT TO BE TRACED, REPRODUCED OR USED IN ANY PROCESS OF MANUFACTURING WITHOUT WRITTEN PERMISSION FROM THE OWNER AND IS RETURNABLE UPON DEMAND. ANY INFRINGEMENT UPON THE PATENT RIGHTS SHOWN HEREIN, WHETHER IN PART OR WHOLE, WILL BE PROSECUTED. AS PART OF OUR POLICY OF CONTINUING DEVELOPMENT, ALLISON PARK GROUP RESERVES THE RIGHT TO ALTER SPECIFICATIONS WITHOUT PRIOR NOTICE.

DESCRIPTION:
Universal Arm, 7.5" Barrel, ACFP

MATERIAL: See detail drawings APPROX. WEIGHT: 1.63

FINISH:
 DRAWN BY: M. Hart DATE: 15 Jun 17 SCALE: NTS SHT-SIZE: A REF. NUMBER:
 CHECKED BY: DATE: PART NUMBER: 35C-AF REVISION: A
 APPROVED BY: DATE: Sheet 1 of 1

REV.	DESCRIPTION	DATE	REV. BY	APPR. BY
REVISIONS				

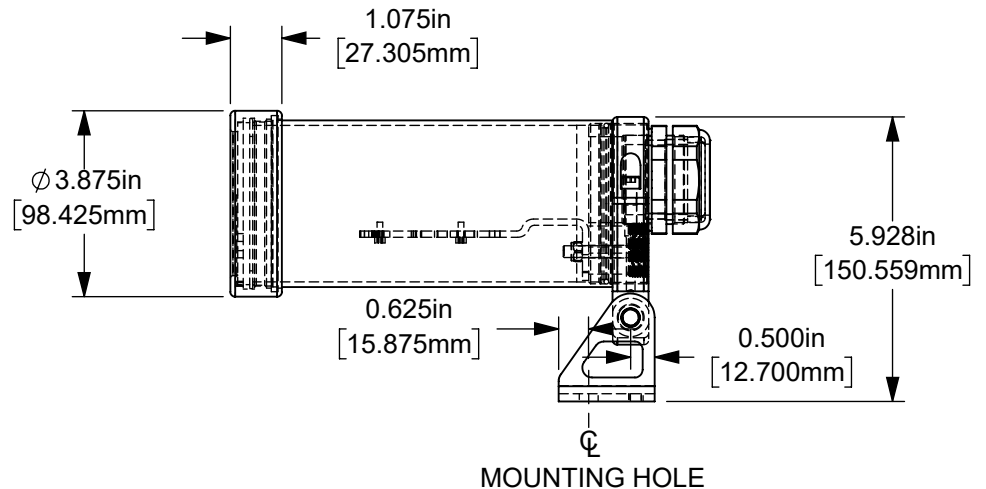
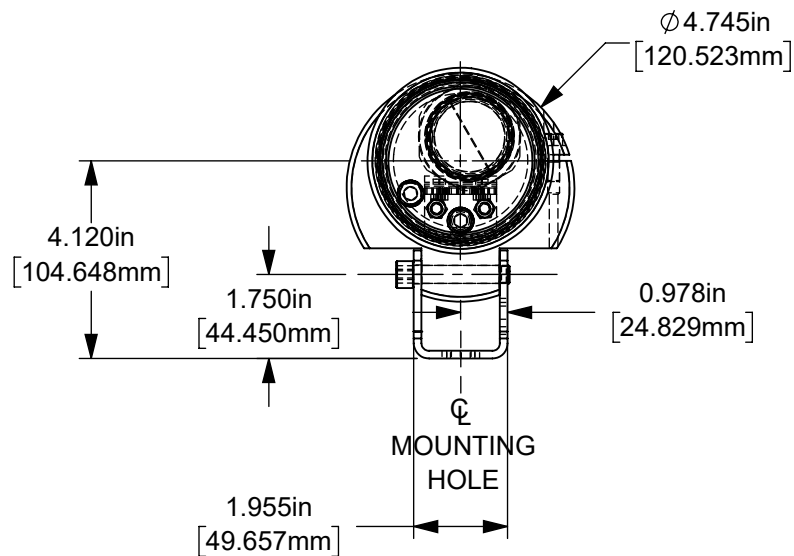
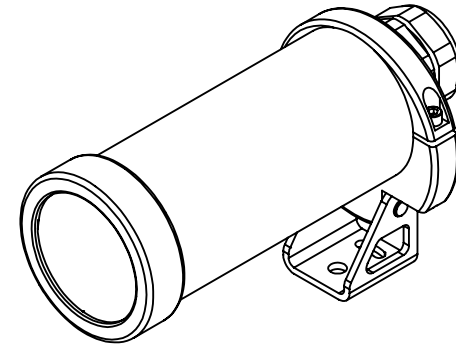
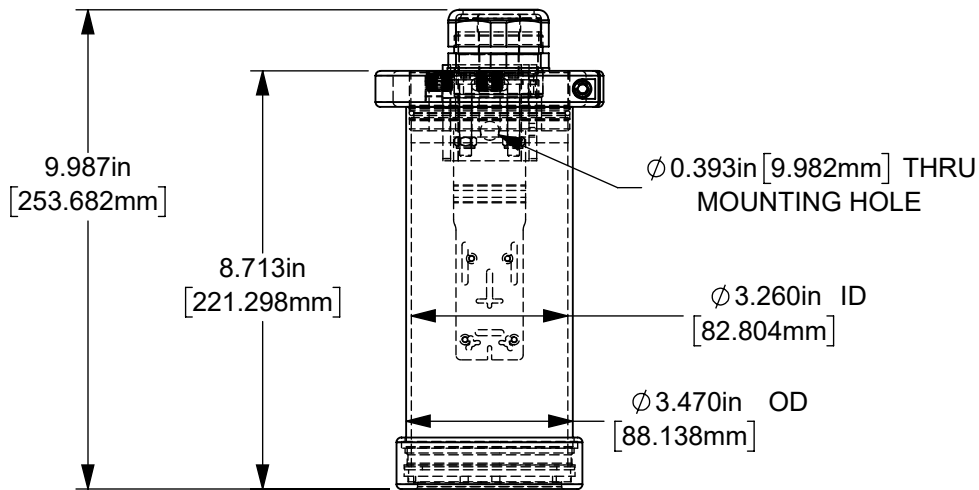

MOUNTING HOLE

TOLERANCES UNLESS OTHERWISE SPECIFIED

MACHINING		SHEETMETAL	
XX	0.0300	XX	± 0.0
XXX	0.0100	XXX	± 0.020
XXXX	0.0050	XXXX	NOTED
XXXXX	0.0005	XXXXX	ANGULAR 0.5°
ANGULAR	0.5°	DEBURR	ALL EDGES
DEBURR	ALL EDGES	ALL WEIGHTS	ARE IN POUNDS



Allison Park Group, Inc (APG)
4055 Alpha Drive
Allison Park, PA 15101 USA
Phone +1 (412) 487-8211
Fax +1 (412) 486-3157

THIS PRINT IS THE PROPERTY OF ALLISON PARK GROUP. THE INFORMATION CONTAINED HEREIN IS CONFIDENTIAL. IT IS NOT TRANSFERABLE. IT IS FURNISHED WITH THE CLEAR UNDERSTANDING THAT IT IS NOT TO BE TRACED, REPRODUCED OR USED IN ANY PROCESS OF MANUFACTURING WITHOUT WRITTEN PERMISSION FROM THE OWNER AND IS RETURNABLE UPON DEMAND. ANY INFRINGEMENT UPON THE PATENT RIGHTS SHOWN HEREIN, WHETHER IN PART OR WHOLE, WILL BE PROSECUTED. AS PART OF OUR POLICY OF CONTINUING DEVELOPMENT, ALLISON PARK GROUP RESERVES THE RIGHT TO ALTER SPECIFICATIONS WITHOUT PRIOR NOTICE.

DESCRIPTION:
Universal Arm, 7.5" Barrel, Sealed

MATERIAL: See detail drawings APPROX. WEIGHT: 1.63

DRAWN BY: M. Hart DATE: 15 Jun 17 SCALE: NTS SHT-SIZE: A REF. NUMBER:
CHECKED BY: DATE: PART NUMBER: 35C-AE REVISION: A
APPROVED BY: DATE: Sheet 1 of 1

REV.	DESCRIPTION	DATE	REV. BY	APPR. BY
REVISIONS				

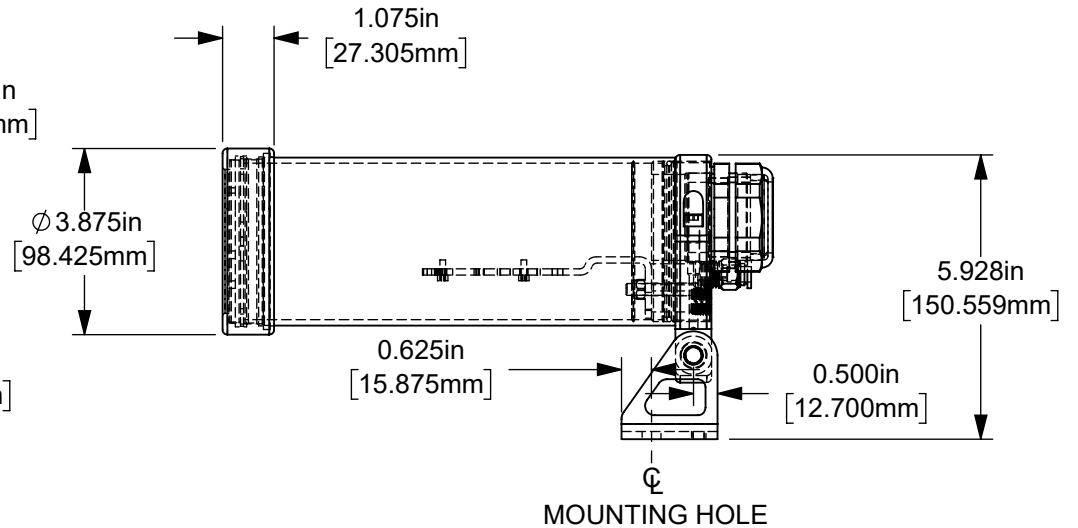
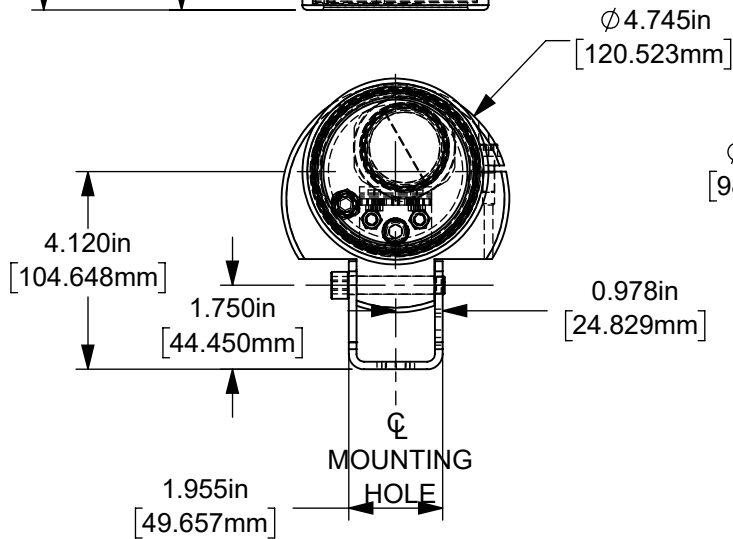
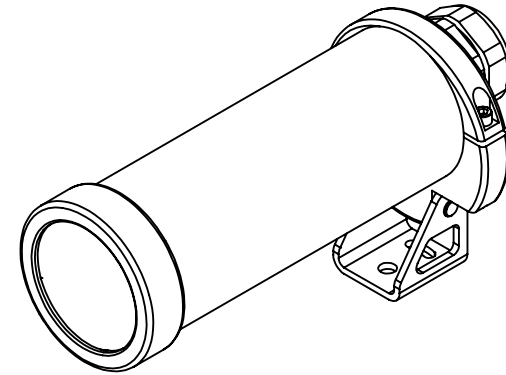
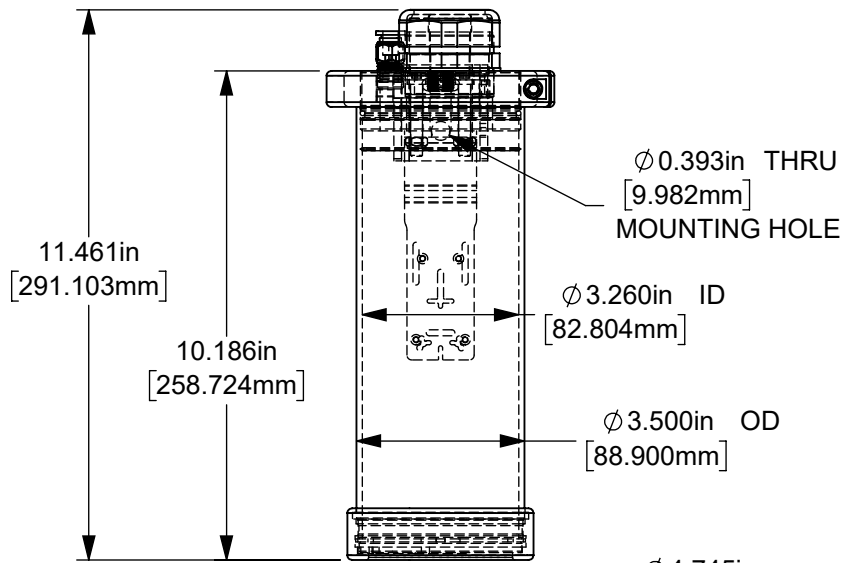

TOLERANCES UNLESS OTHERWISE SPECIFIED

MACHINING		SHEETMETAL	
XX	0.0300	XX	\pm 0.0
XXX	0.0100	XXX	\pm 0.020
XXXX	0.0050	XXXX	NOTED
XXXXX	0.0005	XXXXX	ANGULAR 0.5°
ANGULAR	0.5°	DEBURR	ALL EDGES
DEBURR	ALL EDGES	ALL WEIGHTS	ARE IN POUNDS



Allison Park Group, Inc (APG)
 4055 Alpha Drive
 Allison Park, PA 15101 USA
 Phone +1 (412) 487-8211
 Fax +1 (412) 486-3157

THIS PRINT IS THE PROPERTY OF ALLISON PARK GROUP. THE INFORMATION CONTAINED HEREIN IS CONFIDENTIAL. IT IS NOT TRANSFERABLE. IT IS FURNISHED WITH THE CLEAR UNDERSTANDING THAT IT IS NOT TO BE TRACED, REPRODUCED OR USED IN ANY PROCESS OF MANUFACTURING WITHOUT WRITTEN PERMISSION FROM THE OWNER AND IS RETURNABLE UPON DEMAND. ANY INFRINGEMENT UPON THE PATENT RIGHTS SHOWN HEREIN, WHETHER IN PART OR WHOLE, WILL BE PROSECUTED. AS PART OF OUR POLICY OF CONTINUING DEVELOPMENT, ALLISON PARK GROUP RESERVES THE RIGHT TO ALTER SPECIFICATIONS WITHOUT PRIOR NOTICE.

DESCRIPTION:

Universal Arm, 9" Barrel

MATERIAL:

See detail drawings

APPROX. WEIGHT

1.74

FINISH:

DRAWN BY:

M. Hart

DATE:

19 Jun 17

SCALE:

NTS

SHT-SIZE:

A

REF. NUMBER:

35C-AG

Sheet 1 of 1

APPROVED BY:

DATE:

CHECKED BY:

DATE:

PART NUMBER:

REVISION

A

REV.	DESCRIPTION	DATE	REV. BY	APPR. BY
REVISIONS				

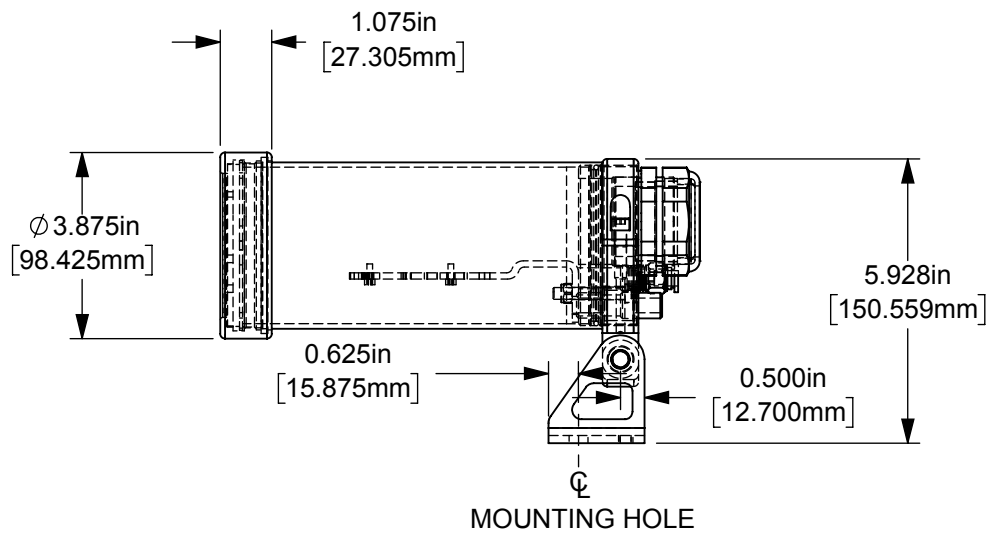
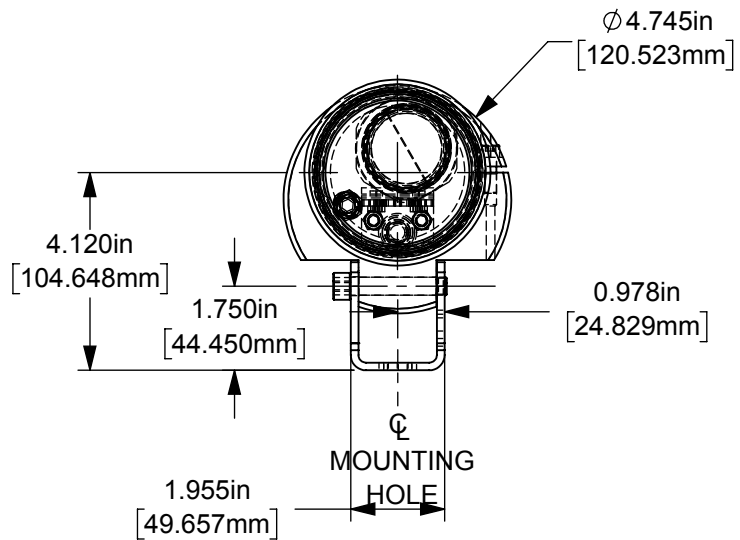
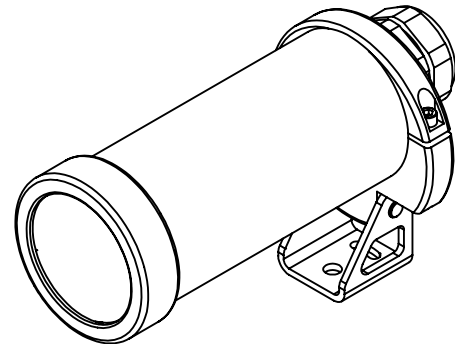
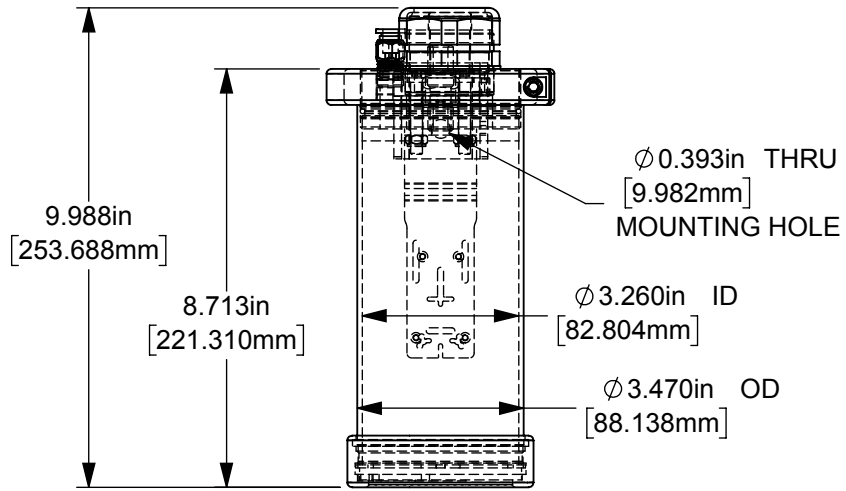

TOLERANCES UNLESS OTHERWISE SPECIFIED

MACHINING		SHEETMETAL	
XX	0.0300	XX	± 0.0
XXX	0.0100	XXX	± 0.020
XXXX	0.0050	XXXX	NOTED
XXXXX	0.0005	XXXXX	ANGULAR 0.5°
ANGULAR	0.5°	DEBURR	ALL EDGES
DEBURR	ALL EDGES	ALL WEIGHTS	ARE IN POUNDS



Allison Park Group, Inc (APG)
 4055 Alpha Drive
 Allison Park, PA 15101 USA
 Phone +1 (412) 487-8211
 Fax +1 (412) 486-3157

THIS PRINT IS THE PROPERTY OF ALLISON PARK GROUP. THE INFORMATION CONTAINED HEREIN IS CONFIDENTIAL. IT IS NOT TRANSFERABLE. IT IS FURNISHED WITH THE CLEAR UNDERSTANDING THAT IT IS NOT TO BE TRACED, REPRODUCED OR USED IN ANY PROCESS OF MANUFACTURING WITHOUT WRITTEN PERMISSION FROM THE OWNER AND IS RETURNABLE UPON DEMAND. ANY INFRINGEMENT UPON THE PATENT RIGHTS SHOWN HEREIN, WHETHER IN PART OR WHOLE, WILL BE PROSECUTED. AS PART OF OUR POLICY OF CONTINUING DEVELOPMENT, ALLISON PARK GROUP RESERVES THE RIGHT TO ALTER SPECIFICATIONS WITHOUT PRIOR NOTICE.

DESCRIPTION:
35C-AH ACRYLIC VIEWPORT

MATERIAL: See detail drawings APPROX. WEIGHT: 1.64

FINISH:
 DRAWN BY: M. Hart DATE: 19 Jun 17 SCALE: NTS SHT-SIZE: A REF. NUMBER:
 CHECKED BY: DATE: PART NUMBER: 35C-AH REVISION: A
 APPROVED BY: DATE: Sheet 1 of 1

REV.	DESCRIPTION	DATE	REV. BY	APPR. BY
REVISIONS				

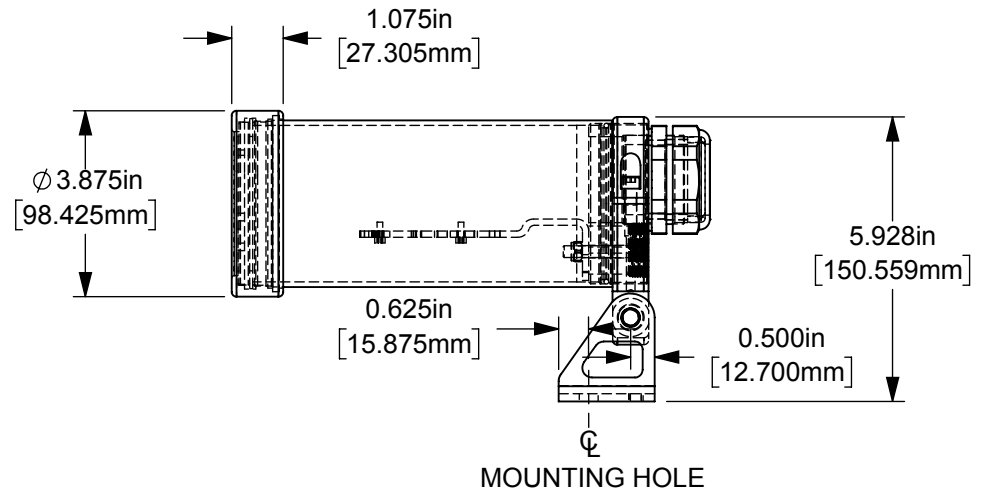
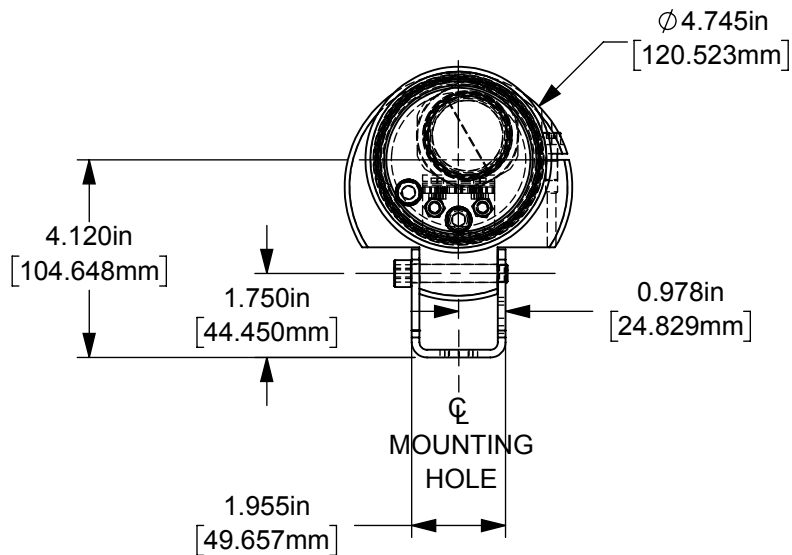
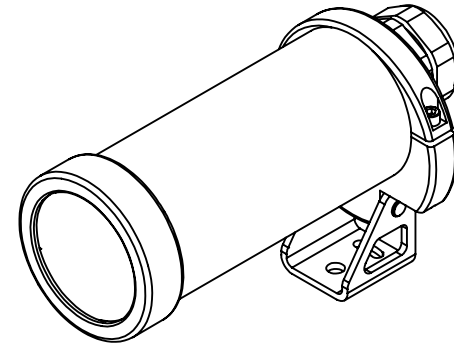
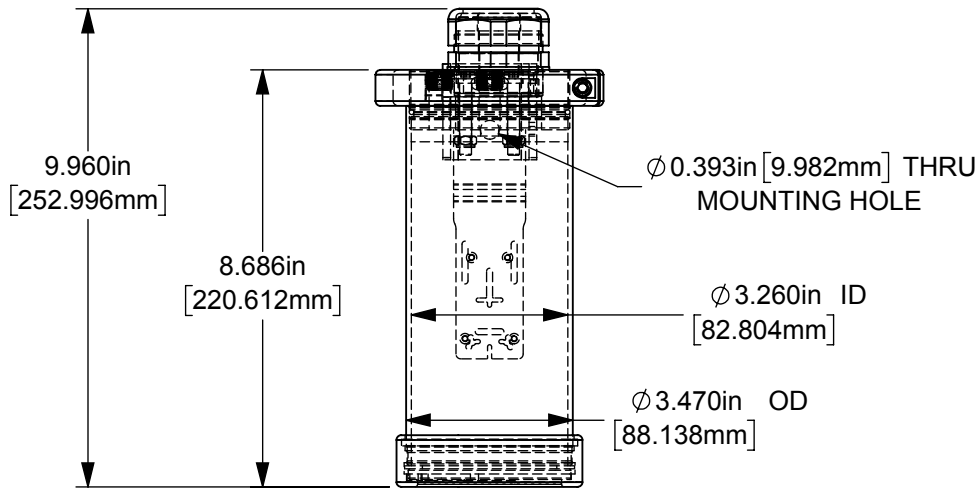

TOLERANCES UNLESS OTHERWISE SPECIFIED				
MACHINING		SHEETMETAL		
XX	0.0300	 ALL WEIGHTS ARE IN POUNDS	XX	± 0.0
XXX	0.0100		XXX	± 0.020
XXXX	0.0050		XXXX	NOTED
XXXXX	0.0005		XXXXX	ANGULAR 0.5° DEBURR ALL EDGES
ANGULAR	0.5°			
DEBURR	ALL EDGES			

MOUNTING HOLE



Allison Park Group, Inc (APG)
 4055 Alpha Drive
 Allison Park, PA 15101 USA
 Phone +1 (412) 487-8211
 Fax +1 (412) 486-3157

THIS PRINT IS THE PROPERTY OF ALLISON PARK GROUP. THE INFORMATION CONTAINED HEREIN IS CONFIDENTIAL. IT IS NOT TRANSFERABLE. IT IS FURNISHED WITH THE CLEAR UNDERSTANDING THAT IT IS NOT TO BE TRACED, REPRODUCED OR USED IN ANY PROCESS OF MANUFACTURING WITHOUT WRITTEN PERMISSION FROM THE OWNER AND IS RETURNABLE UPON DEMAND. ANY INFRINGEMENT UPON THE PATENT RIGHTS SHOWN HEREIN, WHETHER IN PART OR WHOLE, WILL BE PROSECUTED. AS PART OF OUR POLICY OF CONTINUING DEVELOPMENT, ALLISON PARK GROUP RESERVES THE RIGHT TO ALTER SPECIFICATIONS WITHOUT PRIOR NOTICE.

DESCRIPTION: 35C-AK (univ, 7-5 brl, Ait Kit)				
MATERIAL:			APPROX. WEIGHT	
FINISH:				
DRAWN BY: AW	DATE: 5/7/2018	SCALE: NTS	SHT-SIZE: A	REF. NUMBER:
CHECKED BY:	DATE:	PART NUMBER: 35C-AK		REVISION: A
APPROVED BY:	DATE:	Sheet 1 of 1		

REV.	DESCRIPTION	DATE	REV. BY	APPR. BY
REVISIONS				

4

3

2

1

REVISIONS

ZONE	REV.	DESCRIPTION	DATE	APPROVED
	A	RELEASED FOR PRODUCTION	8/9/2019	RS

B

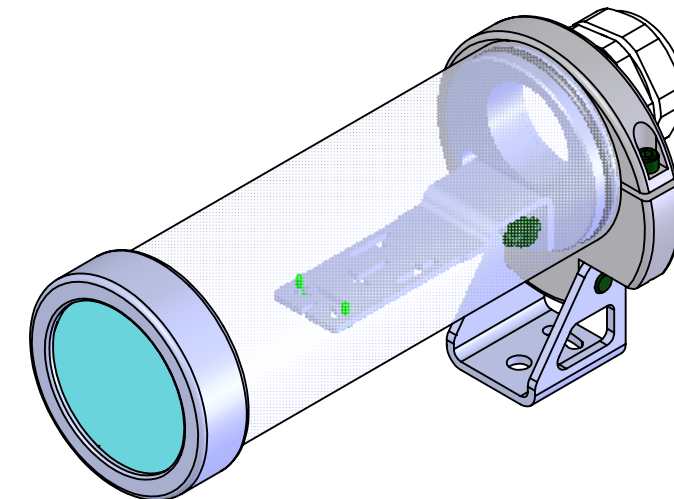
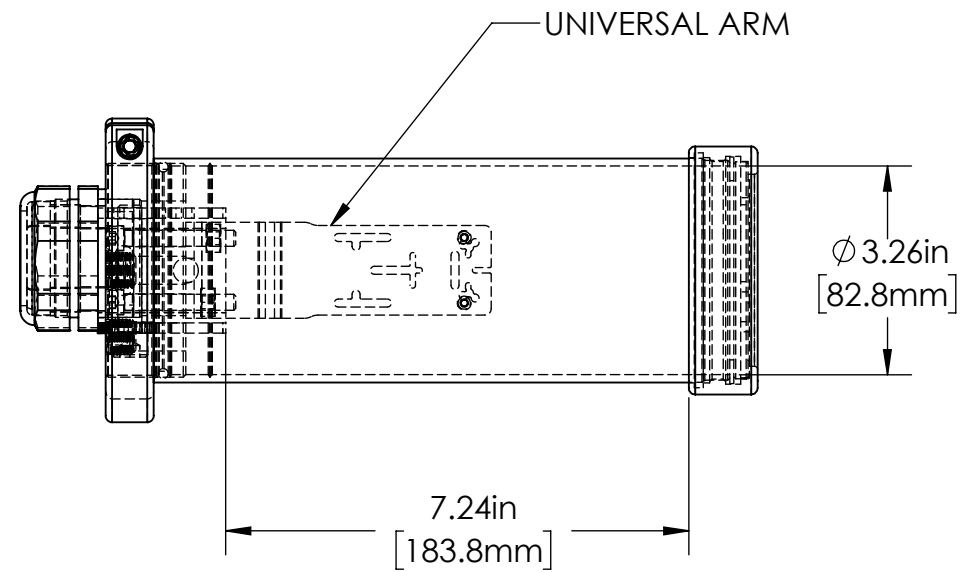

B

A

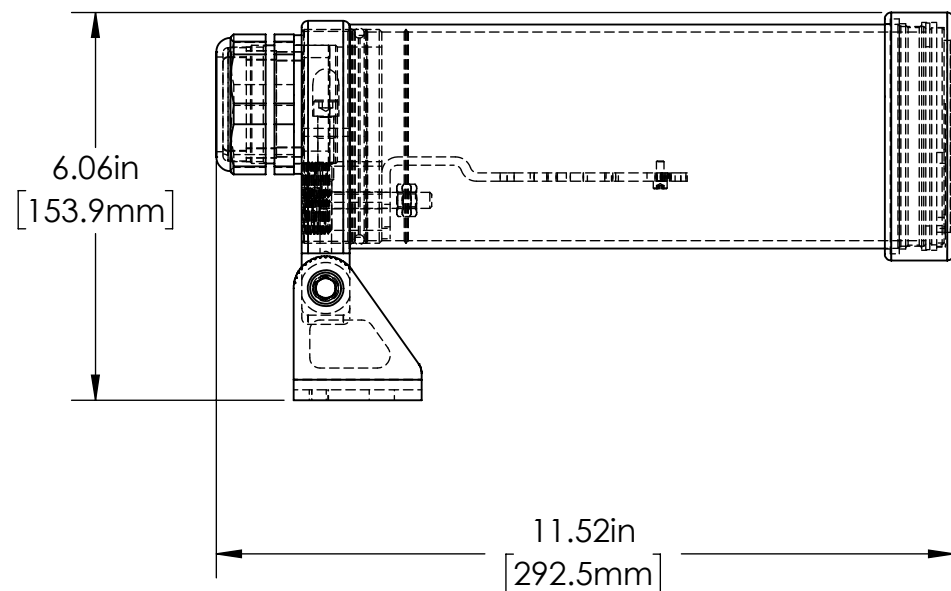

R2.37in [60.3mm]

Ø 3.88in [98.4mm]

1.96in [49.7mm]

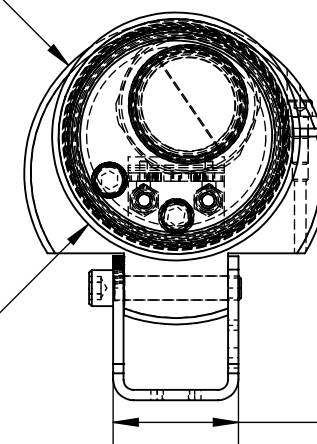

A

TOLERANCES UNLESS OTHERWISE SPECIFIED

MACHINING		SHEET METAL	
X.X	0.0250"	HOLE TO HOLE (SAME SURFACE)	
X.XX	0.0100"	X.X	0.030"
X.XXX	0.0050"	X.XX	0.010"
X.XXXX	0.0005"	X.XXX	0.005"
ANGULAR	0.5°	X.XXX	0.015"
DEBURR ALL		HOLE TO FOLDED EDGE	
		X.X	0.035"
		X.XX	0.025"
		X.XXX	0.015"
		FOLD TO FOLD	
		X.X	0.045"
		X.XX	0.035"
		X.XXX	0.020"
		ANGULAR 1.0°	

ALL WEIGHTS ARE IN POUNDS

THIS PRINT IS THE PROPERTY OF ALLISON PARK GROUP. THE INFORMATION CONTAINED HEREIN IS CONFIDENTIAL. IT IS NOT TRANSFERABLE. IT IS FURNISHED WITH THE CLEAR UNDERSTANDING THAT IT IS NOT TO BE TRACED, REPRODUCED OR USED IN ANY PROCESS OF MANUFACTURING WITHOUT WRITTEN PERMISSION FROM THE OWNER AND IS RETURNABLE UPON DEMAND. ANY INFRINGEMENT UPON THE PATENT RIGHTS SHOWN HEREIN, WHETHER IN PART OR WHOLE, WILL BE PROSECUTED.

AS PART OF OUR POLICY OF CONTINUING DEVELOPMENT, ALLISON PARK GROUP RESERVES THE RIGHT TO ALTER SPECIFICATIONS WITHOUT PRIOR NOTICE.



Allison Park Group, Inc (APG)
 4055 Alpha Drive
 Allison Park, PA 15101 USA
 Phone +1 (412) 487-8211
 apgvision.com

DESCRIPTION:
UNIVERSAL ENCLOSURE - 9 IN BARREL

MATERIAL:
SEE BOM

FINISH: **SEE BOM**

DRAWN BY:	DATE:	SCALE:	SHT-SIZE:	APPROX. WEIGHT
KENNEDY	8/30/2019	1:3	B	1.4878
CHECKED BY:	DATE:	PART NUMBER:		REVISION
		35C-KD		A

4

3

2

1

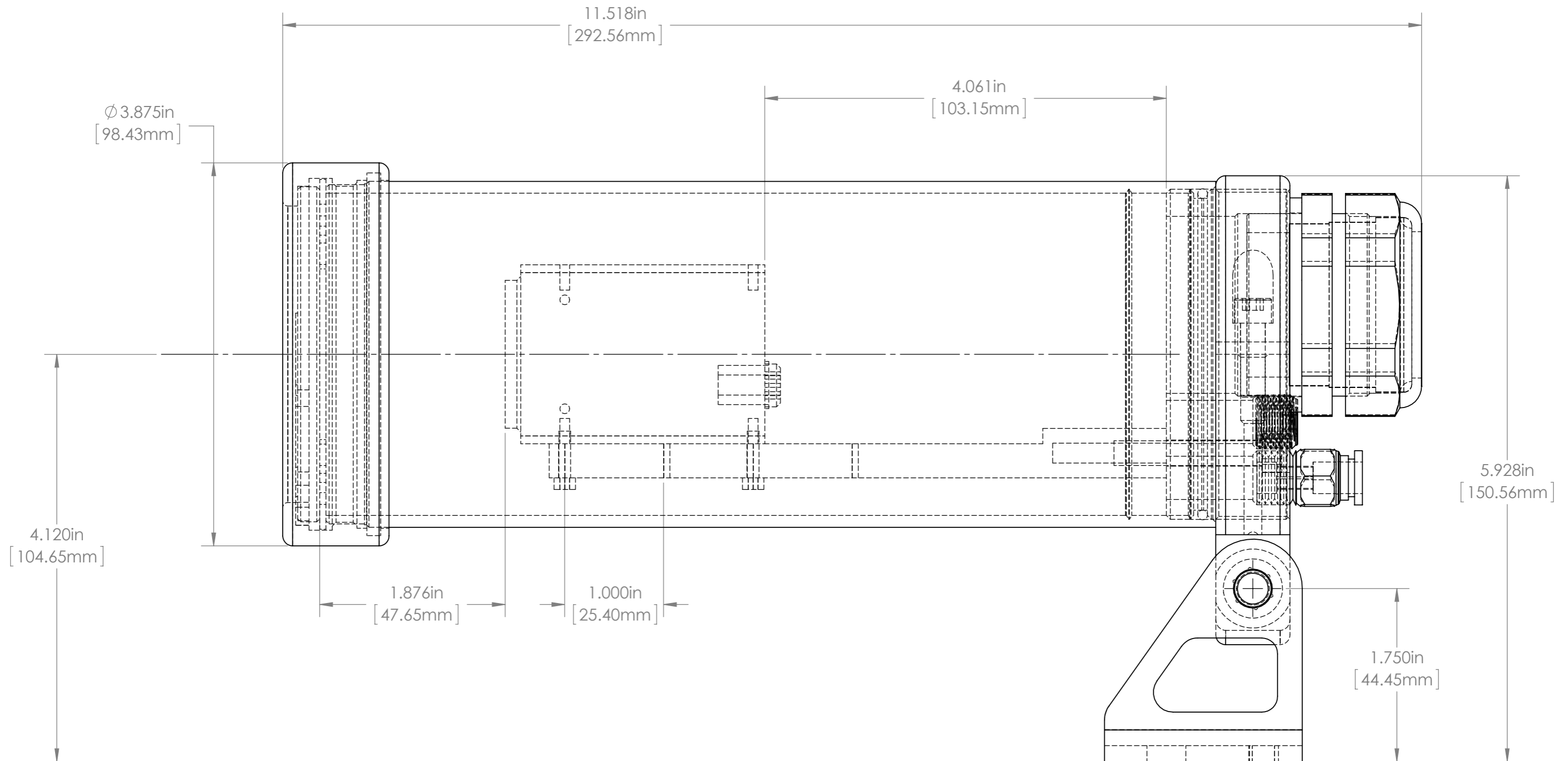

				UNLESS OTHERWISE SPECIFIED: DIMENSIONS ARE IN INCHES SURFACE FINISH: TOLERANCES: .000= +/- 0.005" .00= +/- 0.010"		FINISH: DEBUR AND BREAK SHARP EDGES		DO NOT SCALE DRAWING		REVISION	
				LINEAR:				Allison Park Group, Inc. (APG) 4055 Alpha Drive Allison Park, PA 15101 USA		This document is the property of APG and is considered company confidential. The information in this document is the property of APG and may not be used, reproduced, or distributed in whole or in part without the prior written permission of APG	
				DRAWN		SIGNATURE		Phone +1 (412) 487-8211 Fax +1 (412) 486-3157		TITLE: 35C-KM (Imperx Bobcat 9 in br ACFP)	
				SCHUBERT				www.apgvision.com		DWG NO. 35C-KM ASSY	
				CHK'D				MATERIAL:		SCALE: 1:5	
				APPVD				WEIGHT:		SHEET 1 OF 1	
				MFG						A3	
				Q.A							
				NOTES:							
NO.	CHANGE	DATE	INIT.								

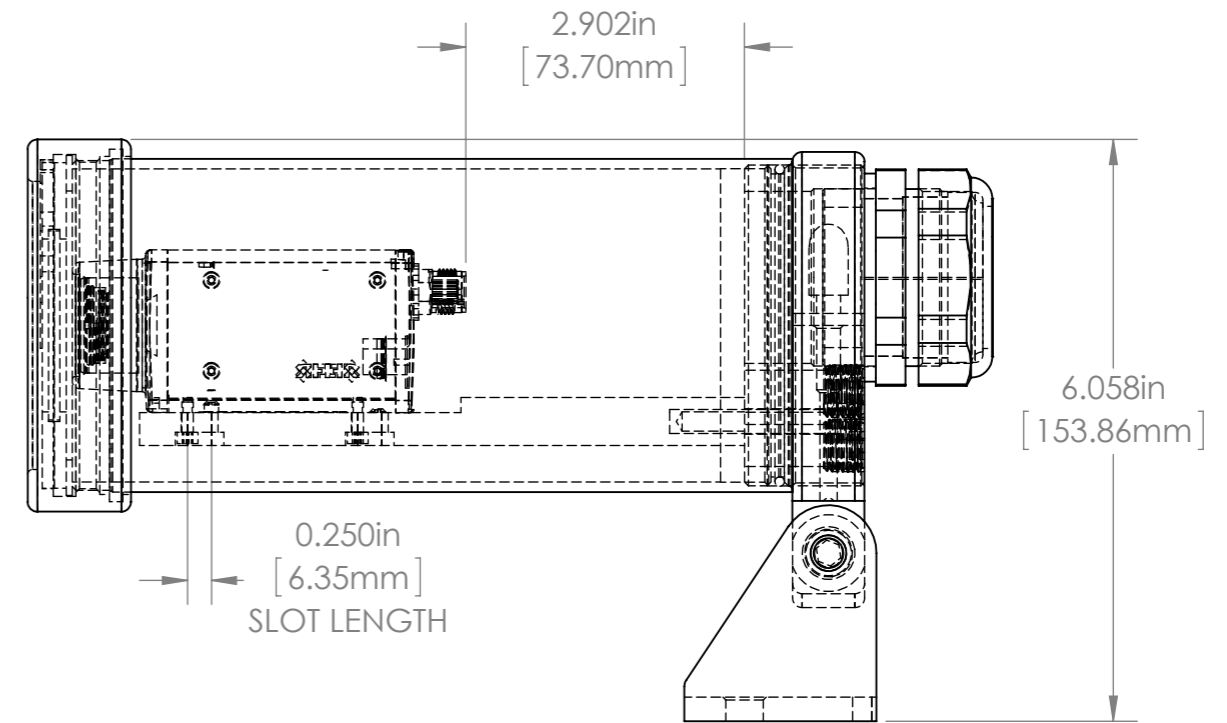
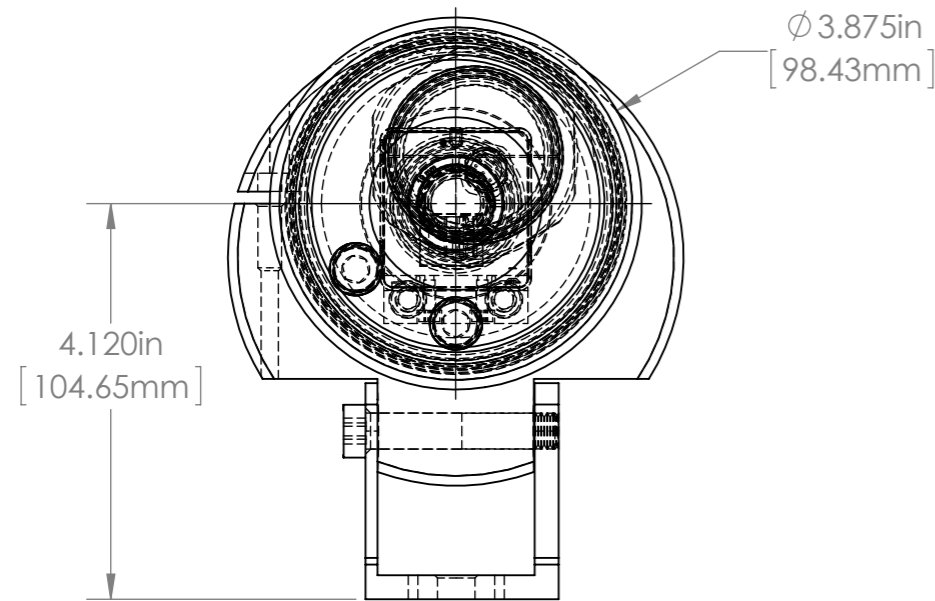
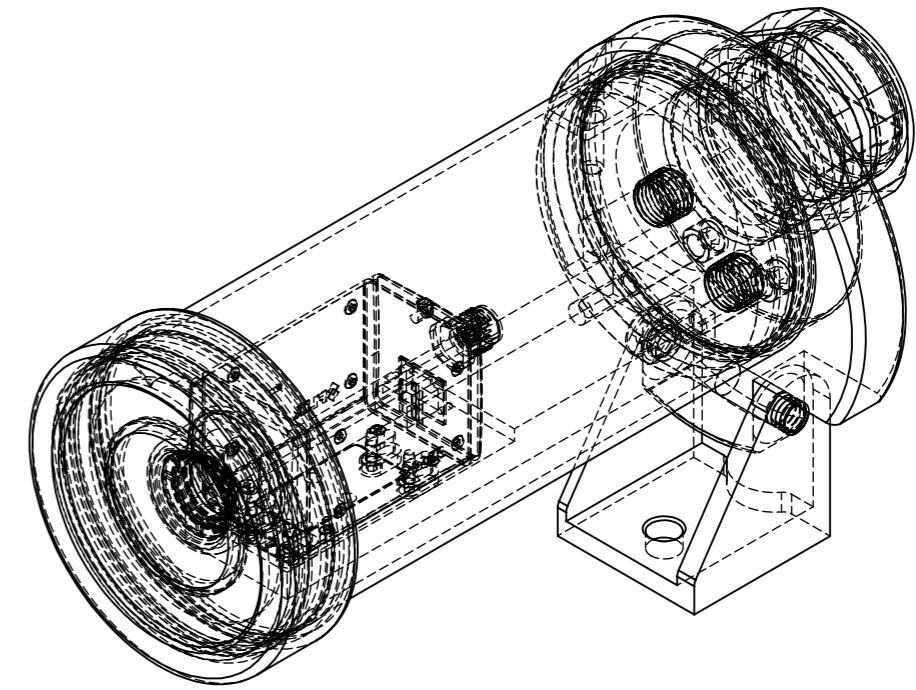
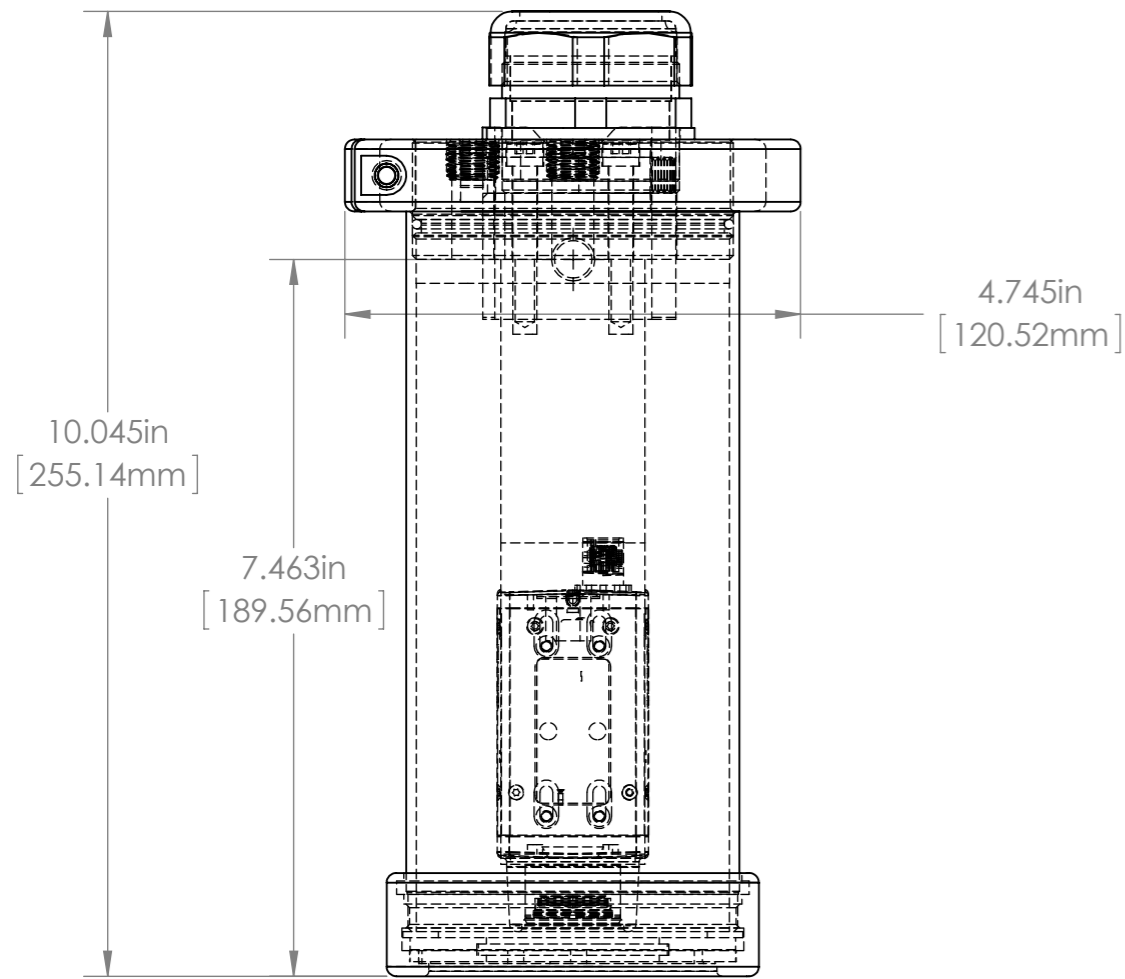

For more information please contact:



BOCK OPTRONICS INC.
 14 Steinway Blvd., Unit 7
 Toronto, Ontario M9W 6M6
 Tel: (416) 674-2804
sales@bockoptronics.ca
www.bockoptronics.ca

UNLESS OTHERWISE SPECIFIED: DIMENSIONS ARE IN INCHES SURFACE FINISH: TOLERANCES: .000= +/- 0.005" .00= +/- 0.010"		FINISH: DEBUR AND BREAK SHARP EDGES	
LINEAR:	NAME	SIGNATURE	DATE
	DRAWN SCHUBERT		6/16/2015
	CHK'D		
	APPVD		
	MFG		
	Q.A		
	NOTES:		
NO.	CHANGE	DATE	INIT.

Allison Park Group, Inc. (APG)
 4055 Alpha Drive
 Allison Park, PA 15101 USA

Phone +1 (412) 487-8211
 Fax +1 (412) 486-3157

www.apgvision.com

MATERIAL:

WEIGHT:

DO NOT SCALE DRAWING

REVISION

This document is the property of APG and is considered company confidential. The information in this document is the property of APG and may not be used, reproduced, or distributed in whole or in part without the prior written permission of APG.

TITLE: **35C-LB 7.5IN ASSY**

DWG NO. **35C-LB ASSY**

A3

SCALE: 1:5

SHEET 1 OF 1