

GIGABIT ETHERNET CABLES FOR USE IN GigE VISION™ APPLICATIONS

PART NUMBER REFERENCE



Select Profile Type:

*Standard Dimension Type: 90 = V

*Extended Dimension Type: 110 = A

Select Connector Type: End "1" (See Pg. 2)

RJ45 Straight = 1	RJ45 HOR. RIGHT EXIIT w/Recessed Screws = 11
RJ45 VRT. w/Thumbscrews = 2	RJ45 HOR. LEFT Exit w/Recessed Screws = 12
RJ45 HOR. w/Thumbscrews = 3	M12 X-Coded 10Gig Male = 13
RJ45 Straight Industrial IP67 = 4	M12 90° Angle –Coded 10 Gig Male = 14
RJ45 R/A DOWN w/Clip = 5	M12 X-Coded 10Gig Female = 15
RJ45 VRT. R/A DOWN w/Recessed Screws = 6	M12 90° Angle –Coded 10 Gig Female = 16
RJ45 HOR. R/A Up w/Thumbscrews = 7	RJ45 Jack = 17
RJ45 HOR. R/A Down w/Thumbscrews = 8	RJ45 Slim Line = 18
RJ45 VRT. RIGHT Exit w/Thumbscrews = 9	IX-10A Industrial Ethernet = 19
RJ45 VRT. LEFT Exit w/Thumbscrews = 10	

Cable Type Options: *

SSTP (CAT 6) = 1	C-Track Cable (CAT 5e) = 4	Industrial (CAT 6a) = 7
Industrial (CAT 5e) = 2	Robotic (CAT 5e) = 5	Ind. HiFlex (CAT 5e) = 8
Extended Distance (CAT 6) = 3	10 GIG Robotic (CAT 6a) = 6	

Select Connector Type: End "2"

RJ45 Straight = 1	RJ45 HOR. RIGHT EXIIT w/Recessed Screws = 11
RJ45 VRT. w/Thumbscrews = 2	RJ45 HOR. LEFT Exit w/Recessed Screws = 12
RJ45 HOR. w/Thumbscrews = 3	M12 X-Coded 10Gig Male = 13
RJ45 Straight Industrial IP67 = 4	M12 90° Angle –Coded 10 Gig Male = 14
RJ45 R/A DOWN w/Clip = 5	M12 X-Coded 10Gig Female = 15
RJ45 VRT. R/A DOWN w/Recessed Screws = 6	M12 90° Angle –Coded 10 Gig Female = 16
HOR. R/A Up w/Thumbscrews = 7	RJ45 Jack = 17
HOR. R/A Down w/Thumbscrews = 8	RJ45 Slim Line = 18
RJ45 VRT. RIGHT Exit w/Thumbscrews = 9	IX-10A Industrial Ethernet = 19
RJ45 VRT. LEFT Exit w/Thumbscrews = 10	

Length in Meters: 1 – 100*

NOTES:

- *Cable type #: 3 is suitable up to 100 meters, all other cable types are suitable up to 60 meters in length.
- *Connectors #: 5-12 & 17-19, are not compatible with cable types #: 7 & 8.
- *Connector type #: 19 is only suitable with cable type #: 2.

PHYSICAL:

- Cable Color: Black, Violet or Teal
- Shell Color: Black
- Shell Construction: Where applicable -Pre-molded in Polyethylene and over-molded in black PVC.
- Fully shielded.
- Cable Construction: Meets EIA/TIA standards, category performance certified.

Temp: 6-9-21

CONNECTOR TYPES:

1



RJ45 Straight

2



RJ45 Vertical
W. Thumbscrews

3



RJ45 Horizontal
W. Thumbscrews

4



RJ45 Straight
IP67 Industrial

5



RJ45 Vertical
W. Thumbscrews

6



RJ45 Vertical R/A
Down W. Screws

7



RJ45 Horizontal Right
Exit W. Thumbscrews

8



RJ45 Horizontal Right
Exit W. Thumbscrews

9



RJ45 Vertical Right
Exit W. Thumbscrews

10



RJ45 Vertical Left
Exit W. Thumbscrews

11



RJ45 Horizontal
Right Exit W. Screws

12



RJ45 Horizontal
Left Exit W. Screws

13



M12 X-Coded
Male Straight

14



M12 90° R/A
X-Coded Male

15



M12 X-Coded
Female Straight

16



M12 90° R/A
X-Coded Female

17



M12 90° R/A
X-Coded Female

18



RJ45 Slim Line

19



IX-10A
Industrial Ethernet

Temp: 6-9-21

TYPE 90

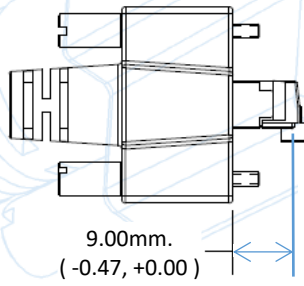

TYPE 110

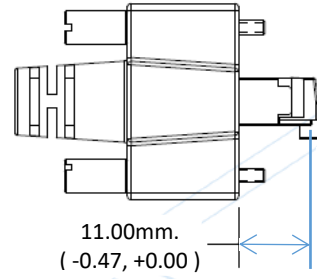

Standard Dimension Type: 90 = V
Extended Dimension Type: 110 = A

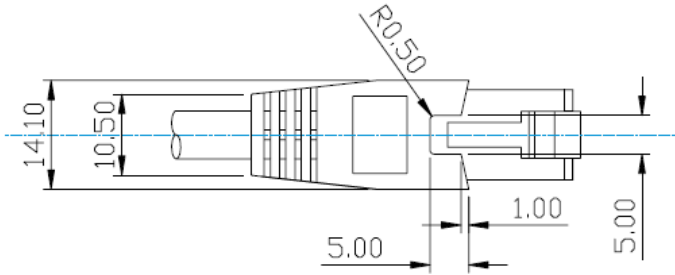

PROFILE 1

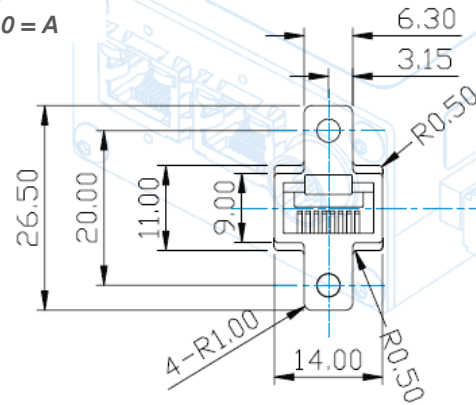

PROFILE 2

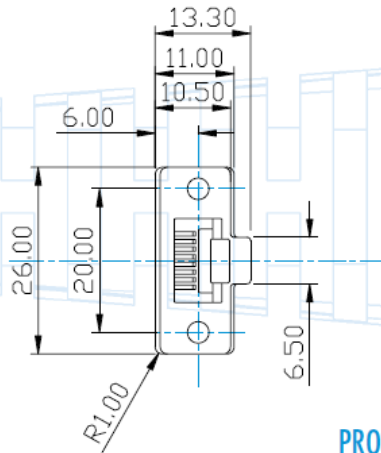

PROFILE 3

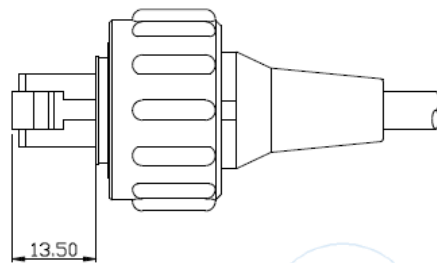
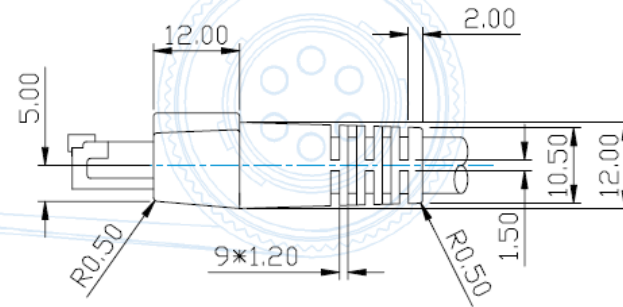

PROFILE 4

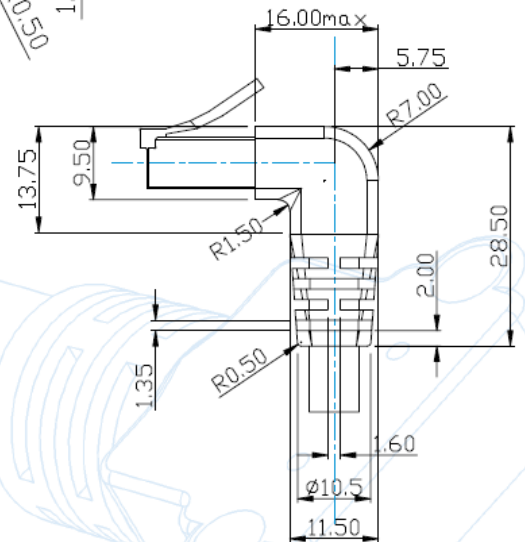

PROFILE 5

Temp: 6-9-21

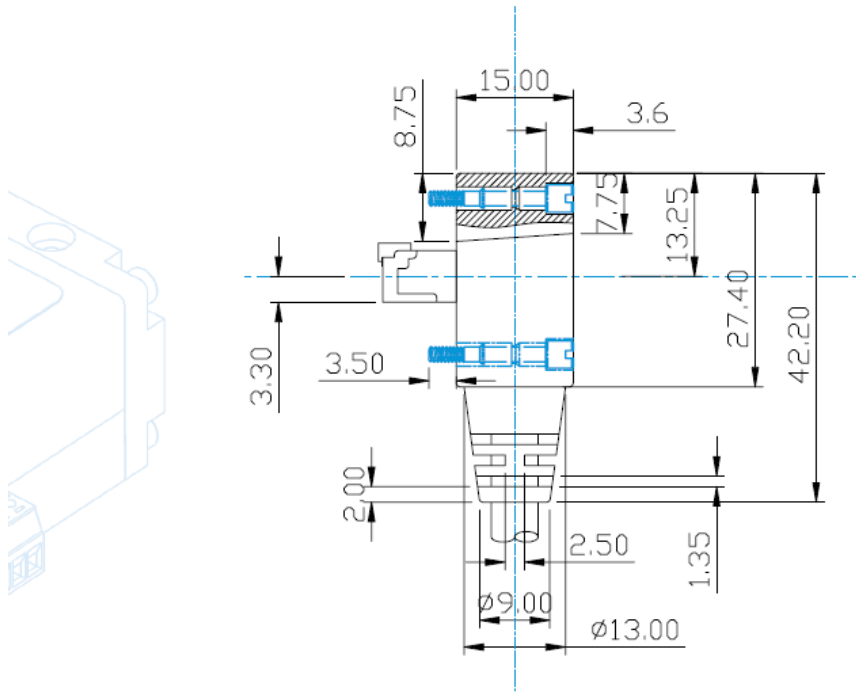

PROFILE 6

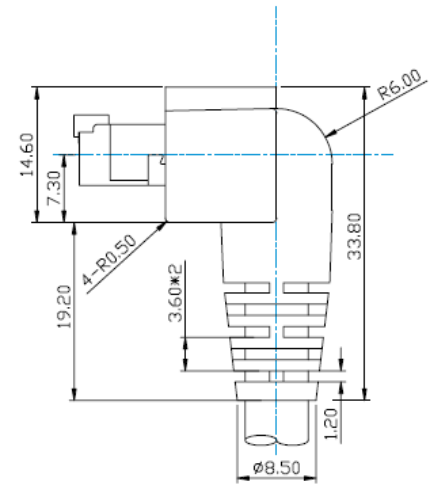

PROFILE 7 & 8

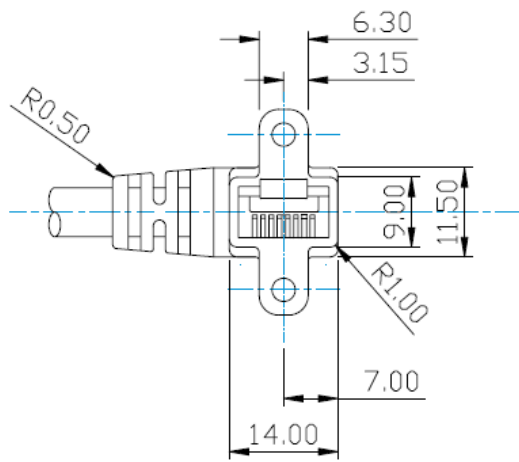

PROFILE 9 & 10

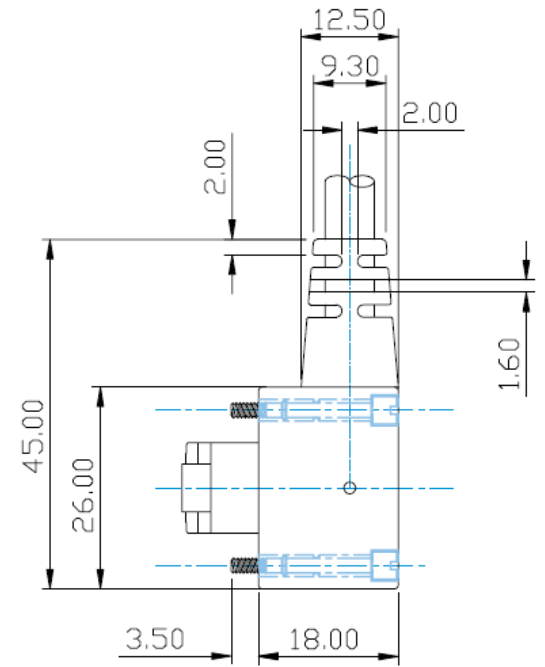

PROFILE 11 & 12

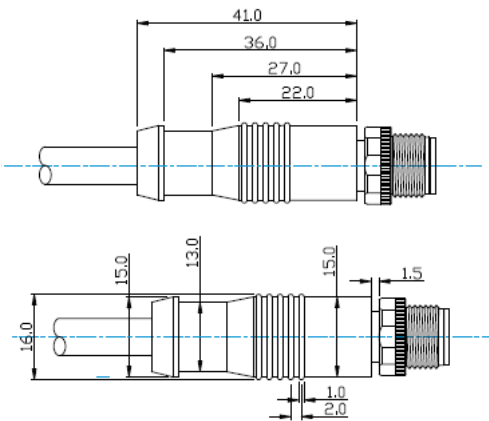



PROFILE 13 & 15

Additional Dimensional Information:

For additional information regarding the physical dimensions of our connector profiles, please visit our Web-Site: www.Componentsexpress.com or ask one our sales associates and we will be happy to assist.

Temp: 6-9-21

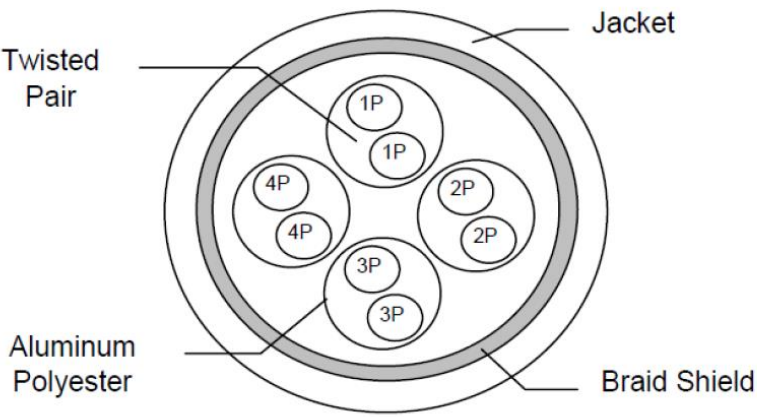
MV Type #: 1 & MI Type #: 5

<p style="text-align: center;">CROSS SECTION</p> 	<p style="text-align: center;">COLOR CODE</p> <p>P1: Blue & White</p> <p>P2: Orange & White</p> <p>P3: Green & White</p> <p>P4: Brown & White</p>
<p style="text-align: center;">DESCRIPTION</p> <p>Rated Temperature: (C°) 75</p> <p>Product Standard Certification: CM</p> <p>Flame Test: FT4</p> <p>Reference Standard: UL 444, & the customer's specification</p> <p>Typical Application: Telephone and other communication circuits such as voice, data and audio for on-premise customer systems.</p>	<p style="text-align: center;">PERFORMANCE</p> <p>Electrical Characteristics: (20°C)</p> <p>Max. Conductor DC Resistance (Ω /km) 142</p> <p>Min. Insulation Resistance (Ω/km) 100</p> <p>Dielectric Strength: AC-500V/1 Min.</p>
<p style="text-align: center;">CONSTRUCTION</p> <p>Conductor: Stranded Bare Copper</p> <p>4 Twisted Pair 8C</p> <p>AWG 26</p> <p>Construction (mm) 7/0.16</p> <p>Stranded Dia. (mm) 0.50</p> <p>Insulation: Skin-Foam-Skin-PE</p> <p>Non. Thickness (mm) 0.26</p> <p>Insulation Dia. (±0.05mm) 1.03</p> <p>Shield: Natural Aluminum / Polyester</p> <p>Coverage (%) ≤ 125%</p> <p>Braid Shield: Tinned Copper</p> <p>Construction (mm) 16/5/0.10T</p> <p>Coverage (%) ≤ 55%</p> <p>Jacket: Polyvinyl Chloride (PVC)</p> <p>Nom. Thickness (mm) 0.58</p> <p>Outer Dia. (+0.2mm) 6.2</p>	<p style="text-align: center;">MECHANICAL CHARACTERISTICS</p> <p>Test Object Jacket</p> <p>Test Material PVC</p> <p>Before Tensile Strength (kg/mm²) ≤ 1.4</p> <p>Aging Elongation (%) ≤ 100</p> <p>Aging Condition 100±2°Cx240 Hrs.</p> <p>After Tensile Strength: ≥85% of original</p> <p>Aging Elongation: ≥50% of original</p> <div style="text-align: center;">  <p>COMPONENTS EXPRESS, INC. 10330 Argonne Woods Drive, Ste 100 Woodridge, IL 60517</p> </div> <p>Spec No. 50255-C</p> <p>Revision C</p> <p>Date 6/13/2011</p> <p style="text-align: center;">MINIMUM BEND RADIUS: 10X O.D.</p> <p style="text-align: center;">8/8/19</p>

MV Type #: 2 & MI Type #: 9

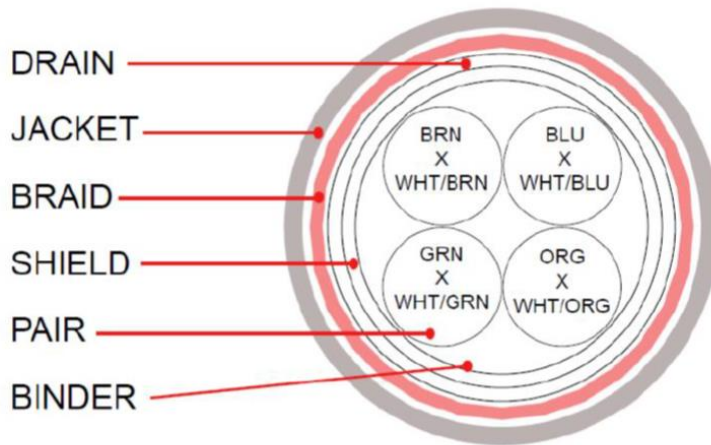

COLOR CODE

1. BLUE X WHITE / BLUE
2. ORANGE X WHITE / ORANGE
3. GREEN X WHITE / GREEN
4. BROWN X WHITE / BROWN

PHYSICAL PROPERTIES

TEMPERATURE RATING, MAX. 75°C (JACKET 105°C)

TEMPERATURE RATING, MIN.: -40°C

JACKET IS RESISTANT TO:

UV, WELD SPLATTER, MACHINE/CUTTING OIL

CONSTRUCTION

CONDUCTOR: 26 AWG 7/34 STRANDED TINNED COPPER

INSULATION: POLYOLEFIN, .010" NOM. WALL THICKNESS

PAIRS: COLOR CODED SINGLES TWISTED INTO PAIRS

CABLE: (4) TWISTED PAIRS TWISTED TOGETHER AND WRAPPED WITH A CLEAR POLYESTER BINDER TO FORM A CABLE CORE.

SHIELDS: AN OVERALL ALUMINIZED POLYESTER FOIL SHIELD (FOIL OUT, 100% COVERAGE) SHALL BE APPLIED OVER THE THE CABLE CORE AND SHALL CONTAIN A 26 AWG 7/34 STRANDED TINNED COPPER DRAIN WIRE IN CONTACT WITH THE METALIZED SURFACE. A SECOND SHIELD OF 38 AWG TINNED COPPER BRAID (85% MINIMUM COVERAGE), SHALL BE APPLIED OVER THE FOIL SHIELD.

JACKET: THERMOPLASTIC ELASTOMER, BLACK, .032" NOM. WALL THICKNESS (PRESURE) OVERALL CABLE DIAMETER .245"

ELECTRICAL CHARACTERISTICS

100m OF CABLE

CAPACITANCE, MUTUAL 13.5 PF/FT. AT 1 MHz

DIELECTRIC WITHSTANDING, MIN 1500V RMS

VOLTAGE RATING, MAX. 300V

D.C. RESISTANCE, MAX. 42.6 Ω/1000'

IMPEDANCE 100 ±15 Ω1 -100 MHz

RETURN LOSS

1 ≤ f < 10 MHz 20 + 5LOG (f) dB MIN

10 ≤ f < 20 MHz 25 dB MIN

20 ≤ f ≤ 100 MHz 25 - 8.6LOG(f/20) dB MIN

MINIMUM BEND RADIUS: 10X O.D.



COMPONENTS EXPRESS, INC.

10330 Argonne Woods Drive, Ste 100
Woodridge, IL 60517

Spec No. **CABLE TYPE #2, INDUSTRIAL HIFLEX TIC-TOC (CAT-5E)**

Revision: **4**

Date: **8/8/19**

PRODUCT SPECIFICATION: EXTENDED DISTANCE CABLE TYPE #: 3**CABLE SPECIFICATIONS****DESCRIPTION** 23 AWG Solid 4 Pair Shielded Twisted Pair High Performance Cable**CONDUCTOR** 23 AWG Solid Annealed Bare Copper**INSULATION** Polyethylene**COLOR CODE** Blue - White/Blue

Orange - White/Orange

Green - White/Green

Brown - White/Brown

SHIELD AI Foil Shield**JACKET** Flame Retardant PVC**JACKET COLOR** Blue Jacket**MARKING CATEGORY** 6E 550MHZ 23AWG 4 PR FTP XXXXXXXX CMR C(ETL)US FT4

ETL LISTED & VERIFIED

TO TIA-568-C.2

OVERALL DIAMETER 0.299' OD Nom.**CABLE WEIGHT** 42 lbs./mft. Nom.**CAPACITANCE** 330pF/100m**IMPEDANCE** 100 +/- 15 Ohms**DC RESISTANCE** 9.38 Ohms/100m**TEMPERATURE RATING** Installation: 0 °C to 60 °C

Operating: -20 °C to 75 °C

INDUSTRY STANDARDS**AGENCY APPROVALS** ETL Listed CMR Type FTP

C(ETL) Listed FT4 FTP

ETL Verified to TIA-568-C.2 and ISO/IEC 11801

RoHS Compliant

MINIMUM BEND RADIUS: 10X O.D.

Components Express, Inc.

Revision: D

Date: 10/12/20

MV Type #: 4 & MI Type #: 8

SHIELDED, OIL RESISTANT, UV-RESISTANT, FLAME RETARDANT, ABRASION RESISTANT

COLOR CODE

1. BLUE & WHITE/BLUE
2. ORANGE & WHITE/ORANGE
3. GREEN & WHITE/GREEN
4. BROWN & WHITE/BROWN

PHYSICAL PROPERTIES

TEMPERATURE RANGE -30°C TO +80°C
 WEIGHT LBS/MFT 60 LBS.
 RoHS COMPLIANT MATERIALS 2002/95/EC
 MIN BEND RADIUS: 12 X OUTER DIAMETER

CONSTRUCTION

CONDUCTOR: 26 AWG FINELY STRANDED BAR COPPER WIRES

INSULATION: FOAM POLYETHYLENE

PAIRS: COLOR CODED, 4 PAIRS TWISTED TOGETHER

CABLE: (4) TWISTED PAIRS TWISTED TOGETHER TO FORM A CABLE CORE.

OUTER JACKET: HALOGEN-FREE, LOW ADHESION BLEND, OUTSIDE DIAMETER .3", COLOR: VIOLET

INNER JACKET: LOW-ADHESION PVC, GUSSET FILLED PRES-SURE EXTRUDED

SHIELD: HIGHLY FLEXIBLE TINNED COPPER, 90% OPTICAL COVERAGE

MINIMUM BEND RADIUS: 10X O.D.

ELECTRICAL CHARACTERISTICS

CAPACITANCE, MUTUAL: 19PF/FT

REGULATIONS: UL AMW: 80°C 300V, CSA AWM: I/II A/B 80°C 300V FT1, CE: IN ACCORDANCE WITH EUROPEAN COUNCIL DIRECTIVE 73/23/EEC, RoHS: 202/95/EC

DIFFERENTIAL IMPEDANCE: 100 OHMS

INSERTION LOSS: MEETS EIA/TIA 568-B.2 FOR CAT5e STRANDED CONDUCTORS



**COMPONENTS
EXPRESS, INC.**

Ph: 800-578-6695
www.ComponentsExpress.com

Spec No. **C-TRACK CABLE TYPE #4**

Revision **A**

Date **9/06/2011** Updated: 8/8/19

MV Type #: 5 & MI Type #: 7

COLOR CODE

1. BLUE X WHITE/BLUE
2. ORANGE X WHITE/ORANGE
3. GREEN X WHITE/GREEN
4. BROWN X WHITE/BROWN

PHYSICAL PROPERTIES

TEMPERATURE RATING, MAX. 75°C
 TEMPERATURE RATING, MIN. -20°C
 WT./M', NOM., NET. 35.6 LBS.
 JACKET IS WELD SPATTER RESISTANT

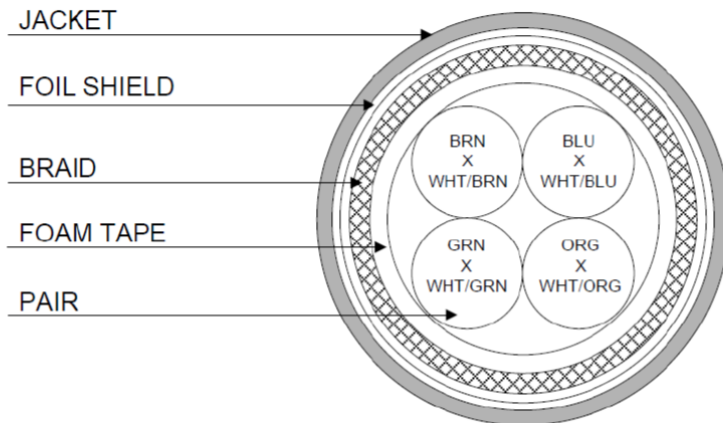

CONSTRUCTION

CONSTRUCTION:		NOM. DIA.
CONDUCTOR:	26 AWG 7/34 STRANDED TINNED COPPER	.019"
INSULATION:	HIGH DENSITY POLYETHYLENE, .009" NOM. WALL THICKNESS	.037"
PAIRS:	COLOR CODED SINGLES TWISTED INTO PAIRS	.074"
CABLE:	(4) TWISTED PAIRS TWISTED TOGETHER AND WRAPPED WITH A FOAM POLYPROPYLENE TAPE TO FORM A CABLE CORE.	
SHIELDS:	AN OVERALL SHIELD OF 38 AWG TINNED COPPER BRAID (75% MINIMUM COVERAGE), SHALL BE APPLIED OVER THE CABLE CORE. A SECOND SHIELD OF ALUMINIZED POLYESTER FOIL (FOIL IN, 100% COVERAGE) SHALL BE APPLIED OVER THE BRAID.	.143"
JACKET:	THERMOPLASTIC ELASTOMER, (BLACK OR VIOLET) , .037" NOM. WALL THICKNESS (PRESSURE)	
	OVERALL CABLE DIAMETER	.245" ± .005"

FLEX & TORSION TESTING

MINIMUM BEND RADIUS: 10X O.D.

FLEX LIFE (126 CYCLES/MIN)	1 MILLION CYCLE TEST (10X CABLE O.D., MINIMUM RADIUS) 10 MILLION CYCLE TEST (20X CABLE O.D., MINIMUM RADIUS)
TORSION TEST (1 LB LOAD, 360°, 71 CYCLES/MIN)	3 MILLION CYCLE TEST
JACKET CUTTING/MACHING OIL RESISTANCE (6 MONTHS @ 20° C)	
TENSILE STRENGTH RETENTION, NOM.	80%
ELONGATION RETENTION, NOM.	100%
POE COMPLIANT (802.3af) TO 80 METERS WHEN INSTALLED PER RECOMMENDATIONS IN TIA TSB-184	

ELECTRICAL CHARACTERISTICS SEE PAGE 2



COMPONENTS EXPRESS, INC.

10330 Argonne Woods Drive, Ste 100
 Woodridge, IL 60517

Spec No. **ROBOTIC CABLE TYPE #5 (CAT 5E)**

Revision **7**

Date **8/8/19**

PRODUCT SPECIFICATION: ROBOTIC CABLE TYPE #5 (CAT 5E)**ELECTRICAL CHARACTERISTICS FOR 100m OF CABLE**

CAPACITANCE, MUTUAL, NOM.	13.5 PF/FT. AT 1 MHz
DIELECTRIC WITHSTANDING, MIN.	1500V RMS
VOLTAGE RATING, MAX.	300V
D.C. RESISTANCE, MAX.	14.0 Ω
IMPEDANCE, NOM.	100 +/- 15 Ω 1-100 MHz
RETURN LOSS	1 - 10 MHz 20 + 6 LOG(f) dB MIN* 10 - 20 MHz 26 dB MIN* 20 - 100 MHz 26- 5 LOG($f/20$) dB MIN*
NEXT	$1 \leq f \leq 100$ MHz 35.3 - 15 LOG($f/100$) dB MIN
PSNEXT	$1 \leq f \leq 100$ MHz 32.3 - 15 LOG($f/100$) dB MIN
ACRF	$1 \leq f \leq 100$ MHz 23.8 - 20 LOG($f/100$) dB MIN
PSACRF	$1 \leq f \leq 100$ MHz 20.8 - 20 LOG($f/100$) dB MIN
INSERTION LOSS	$1 \leq f \leq 100$ MHz $1.5[1.967 \sqrt{f} + 0.023(f) + 0.050/\sqrt{f}]$ dB MAX
DELAY	$1 \leq f \leq 100$ MHz $534 + 36/\sqrt{f}$ ns MAX
DELAY SKEW	$1 \leq f \leq 100$ MHz <25ns
COUPLING ATTENUATION PER IEC 62153-4-9	$30 \leq f \leq 100$ MHz 50 dB MINIMUM
VELOCITY OF PROPAGATION	68%

NOTE: ALL TESTING IS CONDUCTED OFF THE REEL.



COMPONENTS EXPRESS, INC.

10330 Argonne Woods Drive, Ste100
Woodridge, IL 60517

Spec No. **ROBOTIC CABLE TYPE #5 (CAT 5E)**

Revision **7**

Date **8/8/19**

MV Type #: 6 & MI Type #: 6

- 1) CONSTRUCTION:
- | | | | |
|-------------|---|------------------------|--------------------------------------|
| CONDUCTOR: | 26 AWG 7/34 STRANDED TINNED COPPER | NOM. DIA. | .019" |
| INSULATION: | HIGH DENSITY POLYETHYLENE, .009" NOM. WALL THICKNESS | | .036" |
| PAIRS: | COLOR CODED SINGLES TWISTED INTO PAIRS | | .072" |
| CABLE: | (4) TWISTED PAIRS TWISTED TOGETHER WITH A CENTRAL SPLINE AND WRAPPED WITH A FOAM POLYPROPYLENE TAPE TO FORM A CABLE CORE. | | .176" |
| SHIELDS: | AN OVERALL SHIELD OF 38 AWG TINNED COPPER BRAID (80% MINIMUM COVERAGE) SHALL BE APPLIED OVER THE CABLE CORE. AN ALUMINIZED POLYESTER FOIL SHIELD (FOIL IN, 100% COVERAGE) SHALL BE APPLIED OVER THE BRAID SHIELD. | | .195" |
| JACKET: | THERMOPLASTIC ELASTOMER, TEAL, .040" NOM. WALL THICKNESS | OVERALL CABLE DIAMETER | .275" NOM. (± .010")
(BY PI TAPE) |
- 2) PHYSICAL PROPERTIES:
- | | |
|---|--|
| TEMPERATURE RATING, MAX. | 75°C |
| TEMPERATURE RATING, MIN. | -20°C |
| WT./M', NOM., NET. | 41.5 LBS. |
| JACKET IS WELD SPATTER RESISTANT | |
| JACKET IS SUNLIGHT RESISTANT | |
| FLEX LIFE (PENDING) | |
| (126 CYCLES/MIN) | 1 MILLION CYCLE TEST (10X CABLE O.D., MINIMUM RADIUS) |
| | 10 MILLION CYCLE TEST (20X CABLE O.D., MINIMUM RADIUS) |
| TORSION TEST (PENDING) | |
| (1 LB LOAD, 360°, 71 CYCLES/MIN) | 3 MILLION CYCLE TEST |
| JACKET CUTTING/MACHINING OIL RESISTANCE | |
| (6 MONTHS @ 20°C) | |
| TENSILE STRENGTH RETENTION, NOM. | 80% |
| ELONGATION RETENTION, NOM. | 100% |
- 3) ELECTRICAL CHARACTERISTICS:
SEE PAGE 2
- 4) AGENCY APPROVALS:
NEC (UL) TYPE CMX OUTDOOR - CM
CEC C(UL) TYPE CMX OUTDOOR - CM
- 5) APPLICATION:
SHIELDED FLEXIBLE PATCH/JUMPER CABLE TO SUPPORT SCREENED 568-C.2 CATEGORY 6a APPLICATIONS.
RoHS COMPLIANT MATERIALS.

COLOR CODE:

1. BLUE X WHITE/BLUE
2. ORANGE X WHITE/ORANGE
3. GREEN X WHITE/GREEN
4. BROWN X WHITE/BROWN



COMPONENTS EXPRESS, INC.
10330 Argonne Woods Drive, Ste100
Woodridge, IL 60517

Rev. 6

Date: 8/8/19

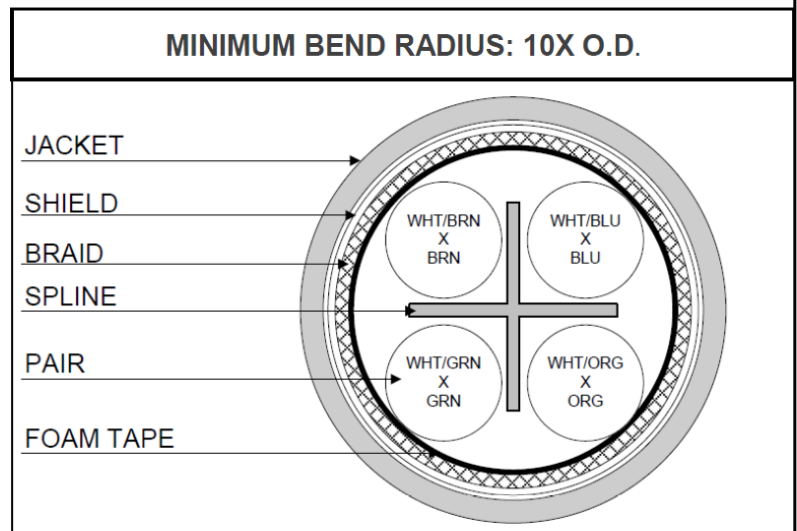

MV Type #: 6 & MI Type #: 6

3) ELECTRICAL CHARACTERISTICS: (FOR 100m OF CABLE)

CAPACITANCE, MUTUAL	13.5 PF/FT. AT 1 MHZ	
DIELECTRIC WITHSTANDING, MIN	1500V RMS	
VOLTAGE RATING, MAX.	300V	
D.C. RESISTANCE, MAX.	14.0 Ω	
IMPEDANCE, NOM.	100 \pm 15 Ω 1 - 100 MHz 100 \pm 20 Ω 100 - 500 MHz	
RETURN LOSS	1 $\leq f < 10$ MHz 20 + 6 LOG(f) dB MIN* 10 $\leq f < 20$ MHz 26 dB MIN* 20 $\leq f \leq 100$ MHz 26 - 5 LOG($f/20$) dB MIN* 100 $< f \leq 250$ MHz 25 - 8.6 LOG($f/20$) dB MIN	
PS NEXT	1 - 500 MHz	42.3 - 15 LOG (F/100) dB MIN
NEXT	1 - 500 MHz	44.3 - 15 LOG (F/100) dB MIN
PS ACRF	1 - 500 MHz	24.8 - 20 LOG(F/100) dB MIN
ACRF	1 - 500 MHz	27.8 - 20 LOG(F/100) dB MIN
ATTENUATION	1 - 500 MHz	1.5[1.82 SQRT(F) + .0091(F) + .25/SQRT(F)] dB MAX
DELAY	1 - 500 MHz	534 + 36/SQRT(F)
DELAY SKEW	1 - 500 MHz	<45 ns
PS ANEXT LOSS (6 AROUND 1)	1 - 500 MHz	62.5 - 15 LOG (F/100) dB 50 - 500 MHz 67 dB 1 - 50 MHz
PS AFEXT (6 AROUND 1)	1 - 500 MHz	38.2 - 20 LOG(F/100) dB
VELOCITY OF PROPAGATION	68%	

NOTE: ALL TESTING IS CONDUCTED OFF THE REEL.



COMPONENTS EXPRESS, INC.
10330 Argonne Woods Drive, Ste 100
Woodridge, IL 60517

Rev. 6

Date: 8/8/19

MV Type #: 7

- 1) CONSTRUCTION: NOM. DIA.
- CONDUCTOR: 24 AWG 7/32 STRANDED TINNED COPPER .0236" .046"
- INSULATION: HIGH DENSITY POLYETHYLENE, .011" NOM. WALL THICKNESS .092"
- PAIRS: COLOR CODED SINGLES TWISTED INTO PAIRS .228"
- CABLE: 4 TWISTED PAIRS TWISTED TOGETHER WITH A CENTRAL SPLINE AND WRAPPED WITH A FOAM POLYPROPYLENE TAPE TO FORM A CABLE CORE. .228"
- SHIELDS: AN OVERALL SHIELD OF 38 AWG TINNED COPPER BRAID (75% MINIMUM COVERAGE), SHALL BE APPLIED OVER THE CABLE CORE. A SECOND SHIELD OF ALUMINIZED POLYESTER FOIL (FOIL IN, 100% COVERAGE) SHALL BE APPLIED OVER THE BRAID. .247"
- JACKET: THERMOPLASTIC ELASTOMER, COLOR BLACK, .039" NOM. WALL THICKNESS (PRESSURE) OVERALL CABLE DIAMETER .325" ± .010" (BY PI TAPE)
- 2) PHYSICAL PROPERTIES:
- TEMPERATURE RATING, MAX. 75°C & 80°C
- TEMPERATURE RATING, MIN. -20°C (PER UL 444 COLD BEND)
- TEMPERATURE RATING, MIN. -40°C (MANUFACTURER'S RECOMMENDED)
- WT./M', NOM., NET. 51.2 LBS.
- JACKET IS SUNLIGHT RESISTANT
- JACKET IS WELD SPATTER RESISTANT
- JACKET IS CUTTING/MACHINING OIL RESISTANT (6 MONTHS @ 20°C)
- TENSILE STRENGTH RETENTION, NOM. 80%
- ELONGATION RETENTION, NOM. 100%
- FLEX LIFE (PENDING)
- (126 CYCLES/MIN, @ 20°C)
- TORSION TEST (PENDING)
- (1 LB LOAD, 360°, 71 CYCLES/MIN, @ 20°C) 3 MILLION CYCLE TEST

MINIMUM BEND RADIUS: 10X O.D.
 1 MILLION CYCLE TEST (10X CABLE O.D., MINIMUM RADIUS)
 10 MILLION CYCLE TEST (20X CABLE O.D., MINIMUM RADIUS)

3) ELECTRICAL CHARACTERISTICS: SEE PAGE 2

4) AGENCY APPROVALS:

NEC (UL) TYPE CMX OUTDOOR - CM
 CEC C(UL) TYPE CMX OUTDOOR - CM

5) APPLICATION:

SHIELDED FLEXIBLE PATCH/JUMPER CABLE TO SUPPORT SCREENED INDUSTRIAL ETHERNET/IP TIA-568.2-D CAT6 & 6a

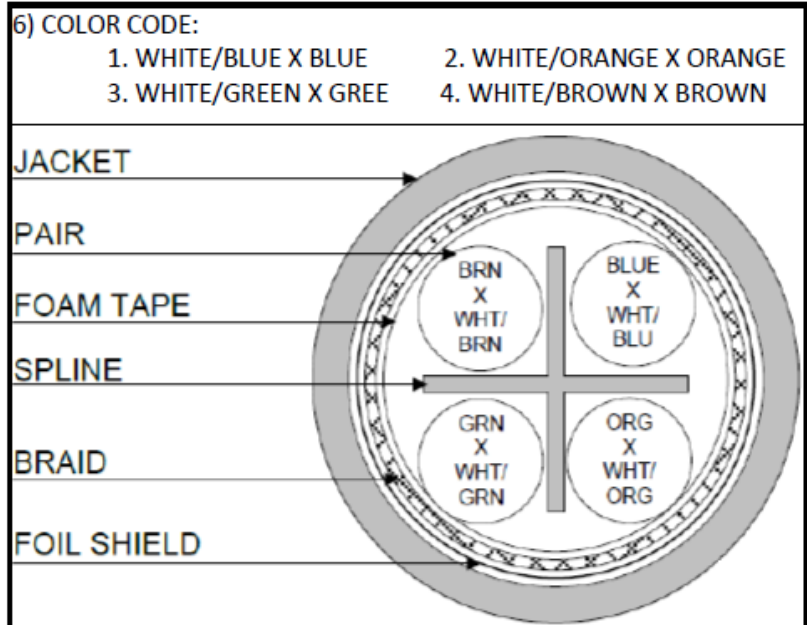

COMPONENTS EXPRESS, INC.
 10330 Argonne Woods Drive, Ste100
 Woodridge, IL 60517

Rev. 3, 4/8/19

MV Type #: 7

6) ELECTRICAL CHARACTERISTICS:

POE COMPLIANT TO 88 METERS WHEN INSTALLED PER RECOMMENDATIONS IN TIA TSB-184

CABLE WILL MEET CAT 6a CHANNEL REQUIREMENTS TO 88 METER LENGTH

CAPACITANCE, MUTUAL, NOM.	13.5 PF/FT. AT 1 MHz
DIELECTRIC WITHSTANDING, MIN.	2000V RMS
VOLTAGE RATING, MAX.	600V
D.C. RESISTANCE, MAX.	26.2 Ω /1,000'

NOTE: TESTING FOR THE FOLLOWING IS CONDUCTED OFF THE REEL. (FOR 100m OF CABLE)

IMPEDANCE, NOM.	100 \pm 15 Ω 1 - 100 MHz	
	100 \pm 20 Ω 100 - 500 MHz	
RETURN LOSS	1 \leq f < 10 MHz	20 + 6 LOG(f) dB MIN*
	10 \leq f < 20 MHz	26 dB MIN*
	20 \leq f < 100 MHz	26 - 5 LOG(f/20) dB MIN*
	100 \leq f \leq 500 MHz	25 - 8.6 LOG(f/20) dB MIN
PS NEXT	1 \leq f \leq 500 MHz	42.3 - 15 LOG(f/100) dB MIN
NEXT	1 \leq f \leq 500 MHz	44.3 - 15 LOG(f/100) dB MIN
PSACRF	1 \leq f \leq 500 MHz	24.8 - 20 LOG(f/100) dB MIN
ACRF	1 \leq f \leq 500 MHz	27.8 - 20 LOG(f/100) dB MIN
INSERTION LOSS	1 \leq f \leq 500 MHz	1.2 [1.82 \sqrt{f}] + 0.0091(f) + 0.25/ \sqrt{f}] dB MAX
DELAY	1 \leq f \leq 500 MHz	534 + 36/ \sqrt{f} ns MAX
DELAY SKEW	1 \leq f \leq 500 MHz	<45 ns
PS NEXT LOSS (6 AROUND 1)	1 \leq f \leq 500 MHz	62.5 - 15 LOG (f/100) dB MIN 50 - 500 MHz 67 dB MIN 1 - 50 MHz
PSAACRF	1 \leq f \leq 500 MHz	38.2 - 20 LOG(f/100) dB MIN
COUPLING ATTENUATION	30 \leq f \leq 250 MHz	100 - 20 LOG(f) (MAX 60 dB) E3*
VELOCITY OF PROPAGATION		68%



COMPONENTS EXPRESS, INC.

10330 Argonne Woods Drive, Ste100
Woodridge, IL 60517

Rev. 3, 4/8/19

MV Type #: 8 & MI Type #: F

- 1) CONSTRUCTION: NOM. DIA. .0280"
 CONDUCTOR: 22 AWG 19/.0058 STRANDED TINNED COPPER .057"
 INSULATION: HIGH DENSITY POLYETHYLENE, .014" NOM. WALL THICKNESS .092"
 PAIRS: COLOR CODED SINGLES TWISTED INTO PAIRS
 CABLE: 4 TWISTED PAIRS TWISTED TOGETHER WITH A WRAPPED WITH A
 FOAM POLYPROPYLENE TAPE TO FORM A CABLE CORE. .250"
 SHIELDS: AN OVERALL SHIELD OF 38 AWG TINNED COPPER BRAID (75% MINIMUM COVERAGE), SHALL
 BE APPLIED OVER THE CABLE CORE. A SECOND SHIELD OF ALUMINIZED POLYESTER FOIL
 (FOIL IN, 100% COVERAGE) SHALL BE APPLIED OVER THE BRAID. .272"
 JACKET: THERMOPLASTIC ELASTOMER, COLOR TEAL, .041" NOM. WALL THICKNESS
 (PRESSURE) OVERALL CABLE DIAMETER .354" ± .010"
 (BY PI TAPE)
- 2) PHYSICAL PROPERTIES:
 TEMPERATURE RATING, MAX. 75°C & 80°C (JACKET 105°C, 75°C OIL)
 TEMPERATURE RATING, MIN. -40°C (MANUFACTURER'S RECOMMENDED)
 WT./M', NOM., NET. 59.7 LBS.
 JACKET IS SUNLIGHT RESISTANT
 JACKET IS WELD SPATTER RESISTANT
 JACKET IS CUTTING/MACHINING OIL RESISTANT (6 MONTHS @ 20°C)
 TENSILE STRENGTH RETENTION, NOM. 80%
 ELONGATION RETENTION, NOM. 100%
 FLEX LIFE (PENDING)
 (126 CYCLES/MIN, @ 20°C)
- MINIMUM BEND RADIUS: 10X O.D.**
 1 MILLION CYCLE TEST (10X CABLE O.D., MINIMUM RADIUS)
 10 MILLION CYCLE TEST (20X CABLE O.D., MINIMUM RADIUS)
- TORSION TEST (PENDING)
 (1 LB LOAD, 360°, 71 CYCLES/MIN, @ 20°C) 3 MILLION CYCLE TEST
- 3) ELECTRICAL CHARACTERISTICS: SEE PAGE 2
- 4) AGENCY APPROVALS:
 UL AWM STYLE 2463 (80C 600V)
 NEC (UL) TYPE PLTC & ITC
 EU CE MARKS: MEETS EU DIRECTIVE
 2011/65/EU (RoHS II)
- 5) APPLICATION:
 RUGGED PATCH CABLE CAT 5e



COMPONENTS EXPRESS, INC.
 10330 Argonne Woods Drive, Ste100
 Woodridge, IL 60517

Rev. 6, 10/18/19

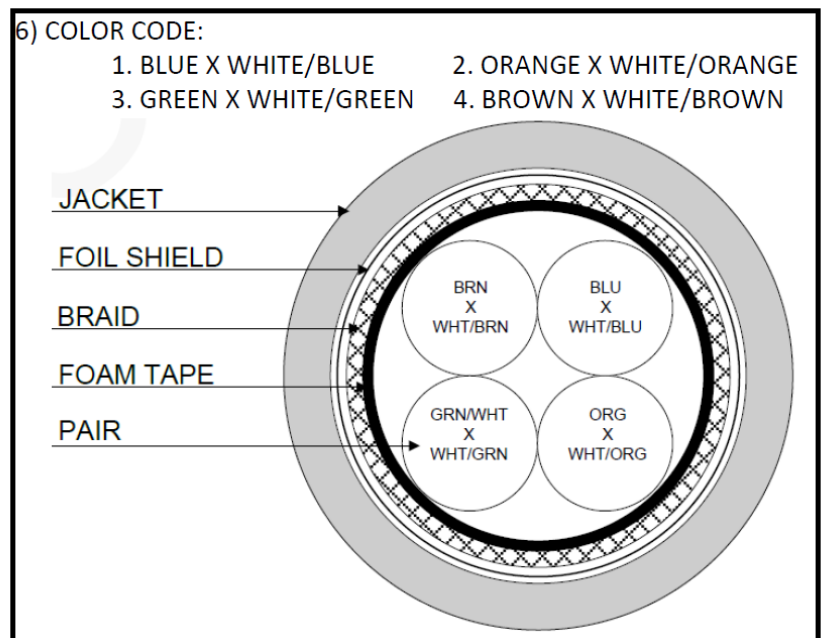

MV Type #: 8 & MI Type #: F

6) ELECTRICAL CHARACTERISTICS:

POE COMPLIANT TO 100 METERS WHEN INSTALLED PER RECOMMENDATIONS IN TIA TSB-184
CABLE WILL MEET CAT 5e CHANNEL REQUIREMENTS TO 100 METER LENGTH

CAPACITANCE, MUTUAL, NOM.	13.5 PF/FT. AT 1 MHz
DIELECTRIC WITHSTANDING, MIN.	2000V RMS
VOLTAGE RATING, MAX.	600V
D.C. RESISTANCE, MAX.	15.9 Ω /1,000' @ 20°C

NOTE: TESTING FOR THE FOLLOWING IS CONDUCTED OFF THE REEL. (FOR 100m OF CABLE)

IMPEDANCE, NOM.	100 \pm 15 Ω 1 - 100 MHz 100 \pm 20 Ω 100 - 500 MHz
RETURN LOSS	1 \leq f < 10 MHz 20 + 6 LOG(f) dB MIN* 10 \leq f < 20 MHz 26 dB MIN* 20 \leq f < 100 MHz 26 - 5 LOG(f/20) dB MIN*
PS NEXT	1 \leq f \leq 100 MHz 32.3 - 15 LOG(f/100) dB MIN
NEXT	1 \leq f \leq 100 MHz 35.3 - 15 LOG(f/100) dB MIN
PSACRF	1 \leq f \leq 100 MHz 20.8 - 20 LOG(f/100) dB MIN
ACRF	1 \leq f \leq 100 MHz 23.8 - 20 LOG(f/100) dB MIN
INSERTION LOSS	1 \leq f \leq 100 MHz 1.02[1.967V(f) + 0.023(f) + 0.050/v(f)] + 4*0.040vf dB MAX
DELAY	1 \leq f \leq 100 MHz 534 + 36/v(f) ns MAX
DELAY SKEW	1 \leq f \leq 100 MHz
(ORG X WHT/ORG, GRN/WHT X WHT/GRN PAIRS)	\leq 20 ns Per IEC 61156-5
(BLU X WHT/BLU, BRN/WHT X WHT/BRN PAIRS)	< 45 ns
COUPLING ATTENUATION	30 \leq f \leq 250 MHz \leq 60 dB) E3*
VELOCITY OF PROPAGATION	69%

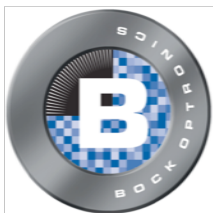

For more information please contact:

BOCK OPTRONICS INC.
14 Steinway Blvd., Unit 7
Toronto, Ontario M9W 6M6

Tel: (416) 674-2804
sales@bockoptronics.ca
www.bockoptronics.ca



COMPONENTS EXPRESS, INC.
10330 Argonne Woods Drive, Ste100
Woodridge, IL 60517

Rev. 6, 10/18/19