

PRODUCT GUIDE



OPTICAL FILTERS & IMAGING SOLUTIONS



CONTENTS

History of Innovation	3
Filter Performance	4—5
Optimal Wavelength	6—7
The MidOpt Difference	8—9
For Machine Vision By Machine Vision	10—11
Bandpass Filters	12—15
Multi-Bandpass Filters	16—17
Dual Bandpass Filters	18—19
Longpass Filters	20—21
Shortpass/NIR-Cut Filters	22—23
Polarizers	24—25
Neutral Density Filters	26—27
Light Balancing Filters	28—29
Acrylic Filters	30—31
Protective Filters	32
Mounting Solutions	33
Filter Kits	34
Accessories & Optics	35
Filter Line-Up	36—39

MIDOPT FILTERS: A NECESSITY, NOT AN ACCESSORY.

MidOpt has more than 30 years of experience in industrial optics and is a worldwide leader in manufacturing filters specially designed for machine vision. MidOpt is represented in over 30 countries, offers more than 3,000 cutting-edge products and serves the following industries:

- Factory Automation
- Security and Surveillance
- License Plate Recognition
- Intelligent Transportation Systems
- Aerial Imaging
- Motion Analysis
- Medical/Life Science
- Scientific Research
- Photography/Cinematography
- 3D Metrology

HISTORY OF INNOVATION

MIDWEST OPTICAL SYSTEMS, INC.

Since the 1980s, MidOpt has designed and manufactured high-quality optical filters for industrial imaging. From our humble beginnings with a single, red machine vision filter in our Singapore office, we quickly expanded to North America and have grown to offer one of the most complete lines of machine vision filters in the world.

In the late 70s, MidOpt Founder Barry Warzak studied under his father Frank, an optical engineer, lens designer and the owner of FJW Optical. With Barry's training and insight into customer needs, he helped launch the machine vision filter market in Singapore. Because of the country's long-standing emphasis on developing high-value manufacturing, many Singaporean companies adopted machine vision technology early on.

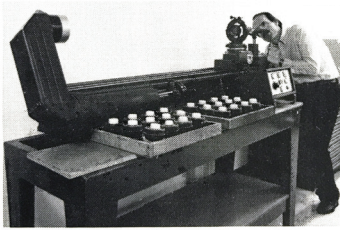

As more companies across the United States, Europe and Asia began introducing machine vision for inspecting semiconductors, electronics and other applications, they were seeking instruction and guidance. The knowledge Barry gained in Singapore was transferred to the MidOpt headquarters in the United States.

Although many companies today market optical filters for industrial imaging, a MidOpt machine vision filter is not just a machine vision filter. In the coming pages, we'll share the key features of a quality machine vision filter and the MidOpt difference when it comes to performance, design and repeatability.

FILTER PERFORMANCE

MidOpt filters are the premier solution for industrial imaging to ensure flawless control, dependable results, unmatched repeatability and exceptional image quality for monochrome and color vision systems.



CONTRAST

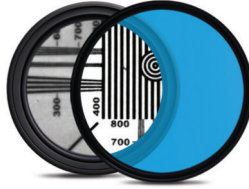

RESOLUTION

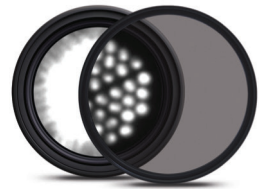

REPEATABILITY

CONTRAST

Filters allow us to selectively pass or block desired wavelengths, which can highlight or darken areas of an image. The ultimate goal is to accentuate the feature we are trying to focus on. Contrast is determined by its dynamic range, recognized as the difference between the lowest and highest intensity level.

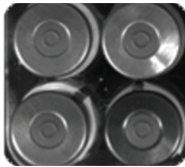

MidOpt BP635 Red Bandpass Filter

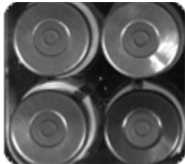
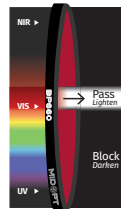

MidOpt BP470 Blue Bandpass Filter

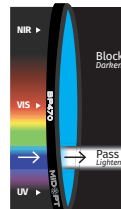

RESOLUTION

Chromatic aberration is a common problem in lenses. It occurs when colors are incorrectly refracted (bent) by the lens, resulting in a mismatch at the focal point – where the colors do not combine as they should. Bandpass Filters improve resolution by reducing the wavelength range of light allowed to pass through the camera, eliminating chromatic aberration. This is even more apparent in broad spectrum imaging where ultraviolet (UV) and infrared (IR) wavelengths are present.

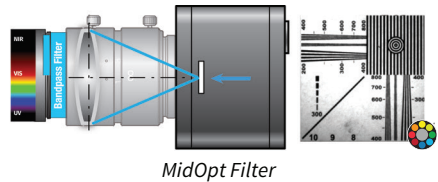
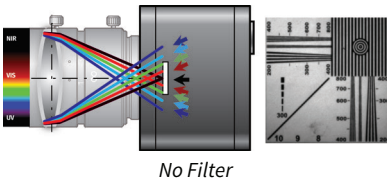
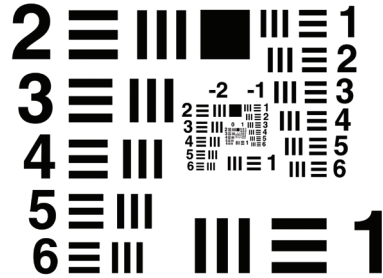

REPEATABILITY

MidOpt filters have the unique ability to control the quality and quantity of light, block all unwanted ambient light, pass only the output of light necessary for inspection and significantly increase contrast and resolution. This results in improved system accuracy, long-term repeatability and unmatched stability.

By including a filter during the vision system design stages, the results achieved in the controlled area of the lab are guaranteed once moved to the variable lighting of the factory floor.

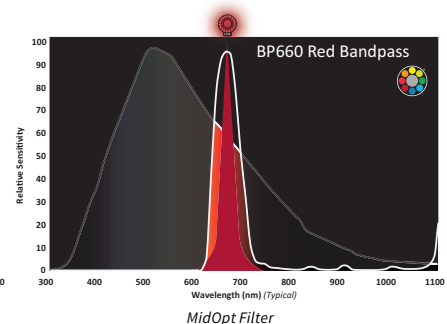
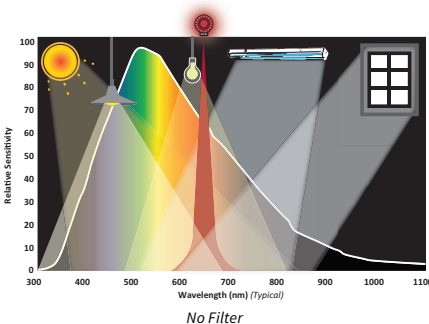

OPTIMAL WAVELENGTH

Test the effects of monochromatic wavelengths by using optical filters together with white light. We can determine the specific wavelength that maximizes contrast and improves the resolution of the feature we want to isolate. Once we obtain that information, we can invest in the proper lighting hardware.

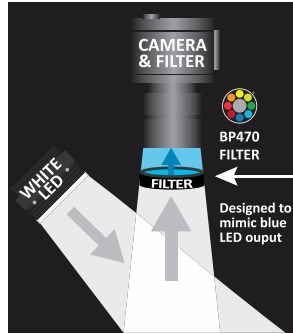
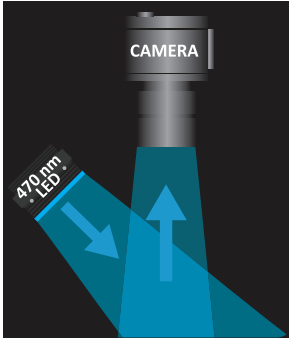

Different filter wavelengths can achieve different results.

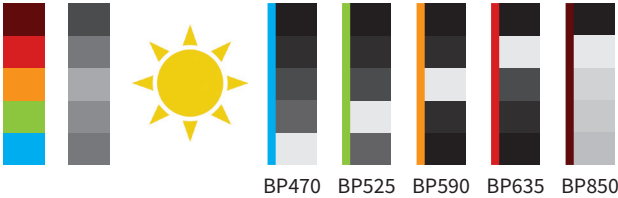

Here's a real-life application with MidOpt filters in action:

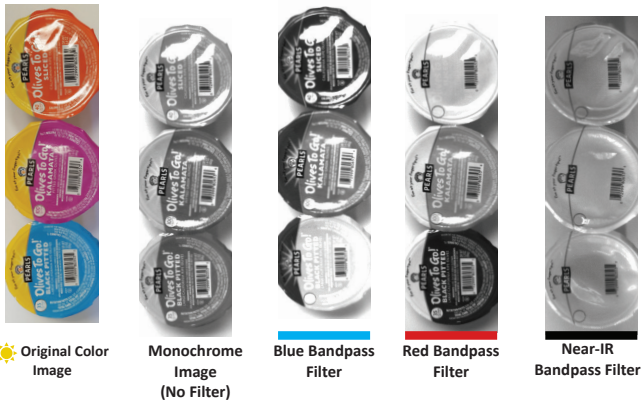

NEAR-IR IMAGING

If the desired image results aren't achieved when testing in the visible spectrum, we recommend testing in the near-infrared (IR). It's impossible to determine the results of near-IR imaging with the human eye alone because we're unable to see in the infrared spectrum; however, the digital sensor is.

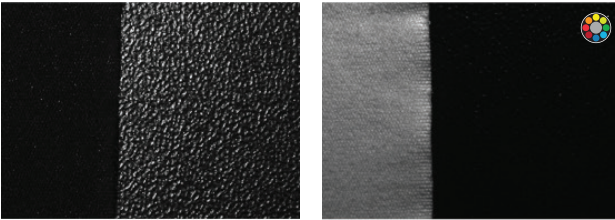
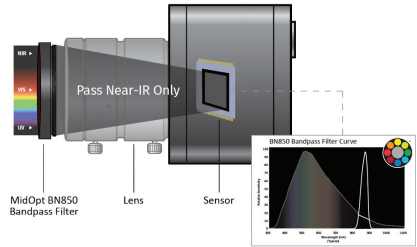

Detecting the separation between two black materials. The fabric on the left reflects infrared light, while the fabric on the right absorbs infrared light, creating contrast.

FLUORESCENCE IMAGING

For a system to be successful in an ultraviolet (UV) fluorescence application, filters must be used to reliably detect the visible emission and block the UV light source. If the fluorescence emission wavelength is unknown, the best way to determine the ideal filter is by testing.

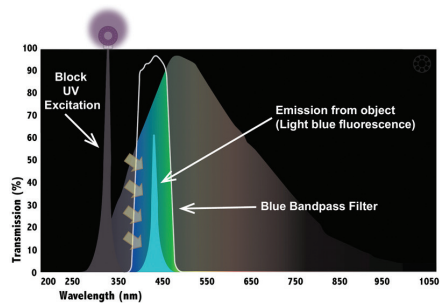

A BP470 Blue Bandpass Filter darkens the background by blocking reflected UV light used to excite the blue fluorescence, creating sufficient contrast.

THE MIDOPT DIFFERENCE



KEY FEATURES OF A QUALITY MACHINE VISION FILTER

A MidOpt machine vision filter is not just a machine vision filter. Here's what to look for when choosing a filter for your machine vision system:

WAVELENGTH CONTROL

Short-shifting occurs when the angle of light passing through a traditional filter increases. This is most commonly seen when the filter is placed in front of a lens with a focal length of 12mm or less (lenses with greater than 50° (±25°) angular fields of view). This accounts for almost 60% of all lenses used today—a number that continues to grow as the demand for space forces inspection footprints to shrink.

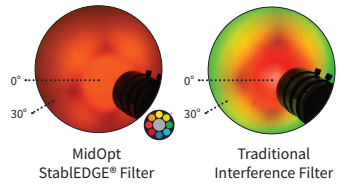
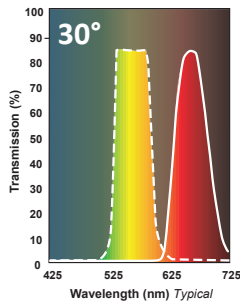
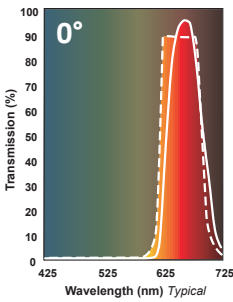

— StablEDGE® Filter - - - Traditional Filter

PASSBAND PERFORMANCE

Some filters on the market have a high, flat transmission profile. With this design, an overwhelming amount of ambient light is able to pass through at the weaker tail ends of the LED spectral output curve. To ensure maximum performance, the position, height and width of the passband should emulate the bell-shaped spectral output curve (Gaussian curve) of the LED illumination being used.

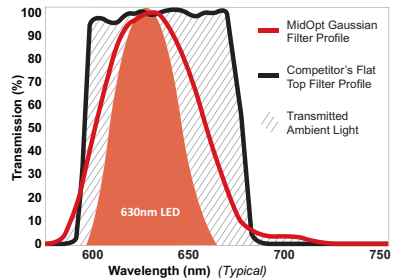

Color Image with Ambient Light



Traditional Red Flat Top Filter



MidOpt Red Gaussian Filter

HIGH-TRANSMISSION ANTI-REFLECTION COATING

When a ray of light passes through a glass surface, a portion of the light is reflected, resulting in a 4% transmission loss per surface. MidOpt uses anti-reflection coating on all filter designs, reducing surface reflection to less than 1%. This improves the efficiency of the vision system by increasing transmission, enhancing contrast and eliminating ghost images.

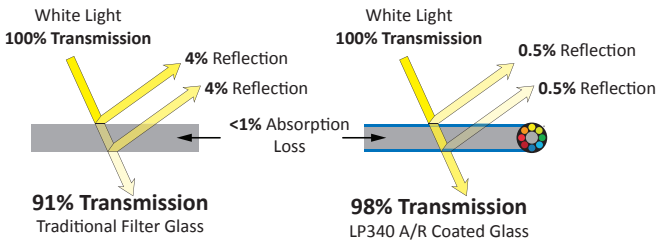

OPTIMAL PERFORMANCE & REPEATABILITY

MidOpt sets the quality standard for machine vision filters. Every filter is examined to ensure near-flawless surface quality and is 100% inspected by state-of-the-art spectrophotometer technology to ensure optimal performance and repeatability. They are also one of the only manufacturers to use controlled torque when securing filters into their mounts, eliminating distortion and guaranteeing optical flatness.

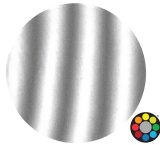

MidOpt Filter
PV: 0.068 wave

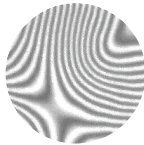

Competitor Filter
PV: 5.131 wave



Good Filter



Reject Filter

MOUNTING SOLUTIONS

MidOpt offers same-day shipping and stocks over 20,000 mounted filters, ranging in size from M13.25 to M105. A variety of other mounting solutions are also available, including options for applications without filter threads, custom mounting solutions and the MidOpt exclusive 25.4[®] C-Mount filter. **See page 33 for a full list of mounting solutions**



For more information, visit midopt.com/key-features

FOR MACHINE VISION BY MACHINE VISION



ROBOTIC ASSEMBLY & INSPECTION SYSTEM

MidOpt unveils an industry first, with the introduction of cutting-edge robotic assembly and inspection technology. Quality and repeatability are ensured by limiting the possibility of human error during the manufacturing and inspection processes.

CONSISTENT QUALITY INSPECTION

The New MidOpt Robotic Assembly and Inspection Station provides consistency and uniformity when inspecting scratches, digs and other cosmetic defects. A greater variety of inspection lighting, increased magnification and additional inspection steps are all utilized, while the variability of individual perception is removed from the inspection equation. This results in pristine optical surfaces and improved image quality. Safeguard your industrial imaging applications with superior optical filtering provided by MidOpt designs and automated assembly and inspection.

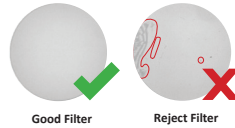
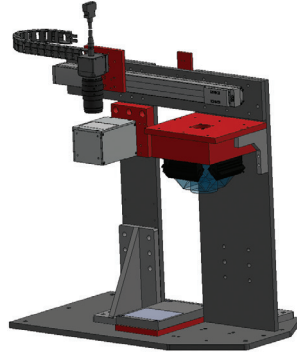

TORQUE CONTROLLED MOUNTING

When assembling optically flat, precision polished filters into threaded filter mounts, interferometric measurements reveal drastic deformations caused by even the slightest amount of stress introduced during assembly. The resulting optical distortion can significantly impact image quality, as seen in the interferometric examples below. The new MidOpt Robotic Assembly Station allows each filter to be gently yet securely held in the filter mount by the retaining ring. After ideal torque is applied, controlled amounts of thread-locking compound are dispensed to prevent the retaining ring from loosening.

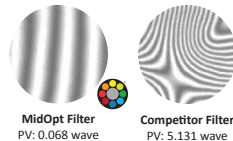
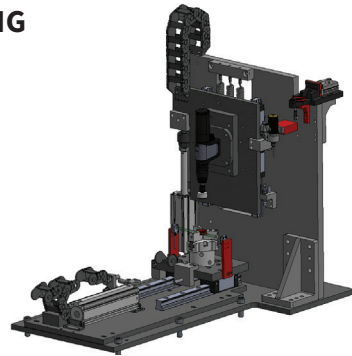

For more information, visit midopt.com/robot

BANDPASS FILTERS

All MidOpt Bandpass filters are double-sided polished for exceptional parallelism and optical flatness. BP and BN series filters are designed with StableEDGE® technology, which offers superior out-of-band blocking, reduces angular dependency and minimizes the effects of short-shifting.

BP SERIES Broad Bandwidth

- 60+nm FWHM*; Peak Transmission $\geq 90\%$
- StableEDGE design with a broad, Gaussian passband to mimic and accommodate the entire output of the most common LED lighting wavelengths

BN SERIES Narrow Bandwidth

- 45-55nm FWHM*; Peak transmission $\geq 85\%$
- StableEDGE design for use with laser diodes and LEDs in applications with overwhelming ambient light

APPLICATIONS: BP and BN Series Filters are used in a variety of industries, including machine vision, factory automation, security and surveillance, license plate recognition, medical and life sciences, agricultural inspection, aerial imaging, motion analysis, photography and cinematography. Test the effects of monochromatic illumination with a BandPass Filter Kit. **See page 34**

Bi SERIES Narrow Interference Bandwidth

- 20-35nm FWHM*; Peak transmission $\geq 85\%$
- StableEDGE design for use with laser diodes
- Ideal wavelength separation when multiple light sources of similar wavelengths are present
- Reflective, mirror-like surface that helps minimize adverse thermal effects

APPLICATIONS: Bi Series are popular for life science and laser analysis applications where only discrete wavelengths need to be passed to maximize system performance.

**Applies in most cases*

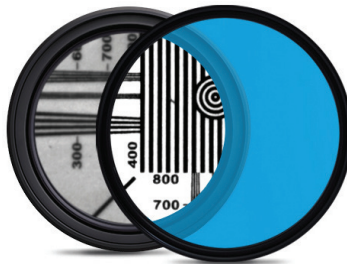

For more information, visit midopt.com/bandpass

FILTERS & TRANSMISSION CURVES

BP SERIES: BROAD BANDWIDTH

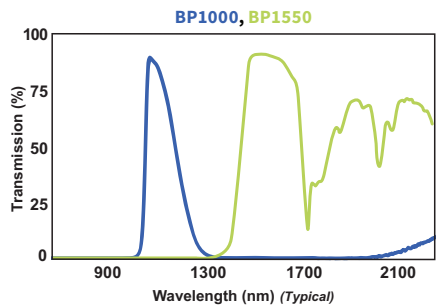
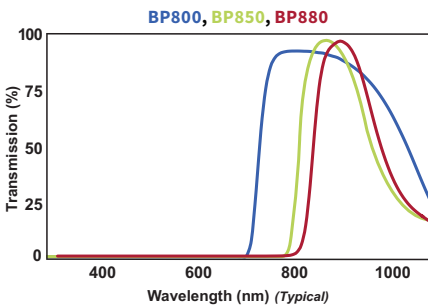
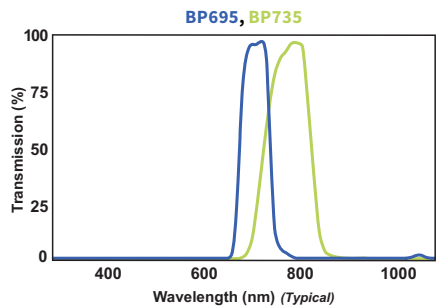
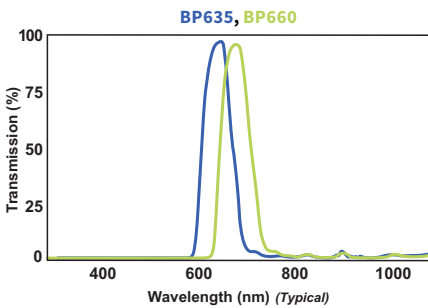
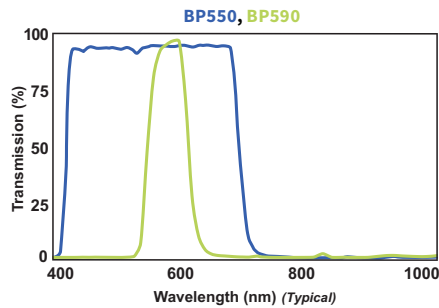
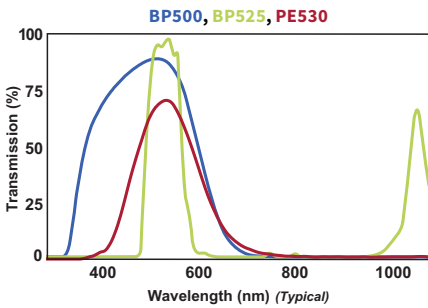
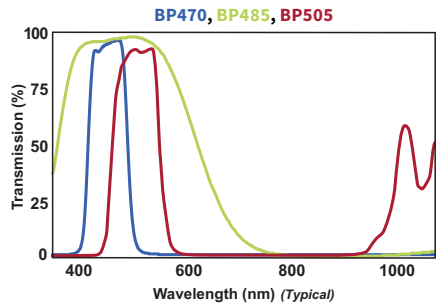
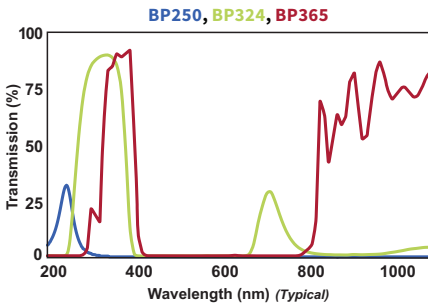

Bandpass

BP

FILTERS & TRANSMISSION CURVES

BN SERIES: NARROW BANDWIDTH

Bandpass
BN

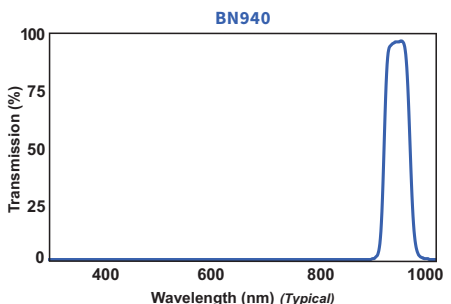
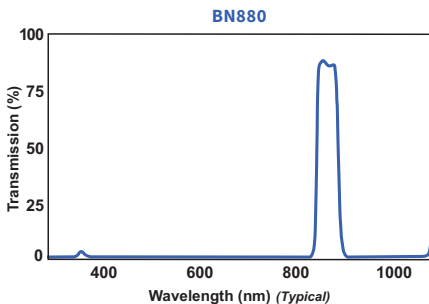
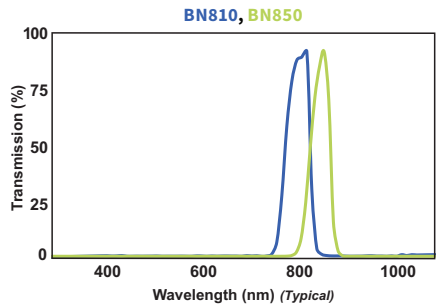
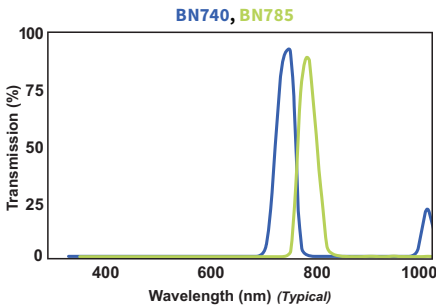
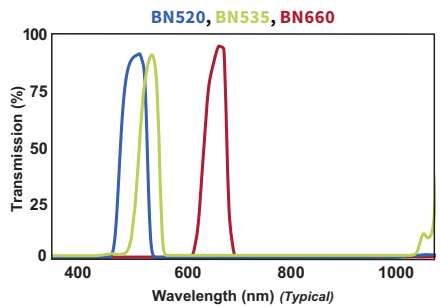
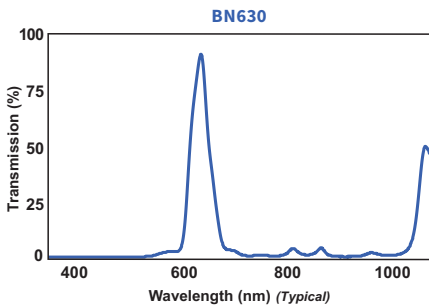
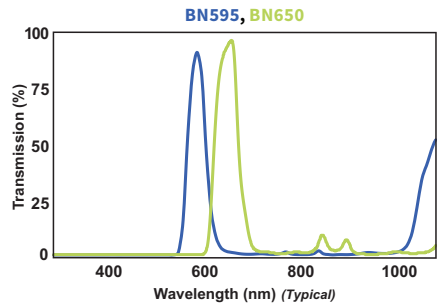
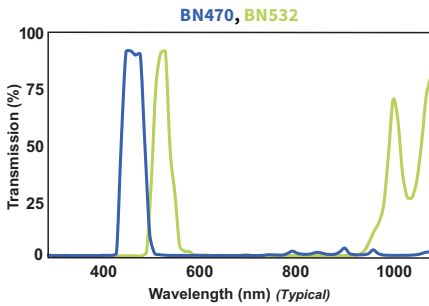

FILTERS & TRANSMISSION CURVES

BI SERIES: NARROW INTERFERENCE

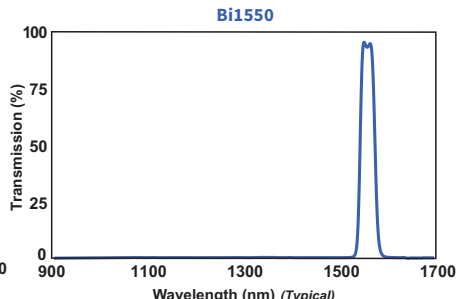
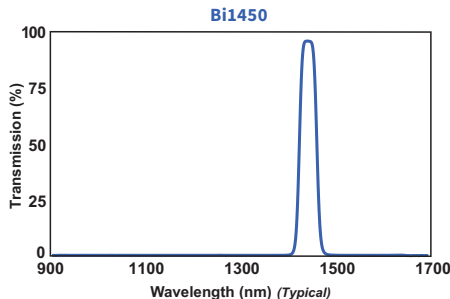
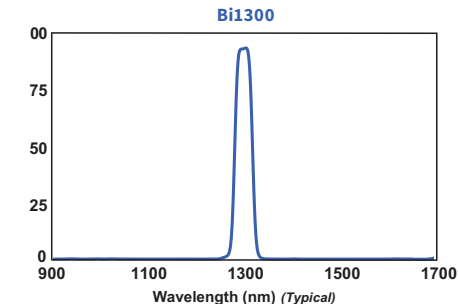
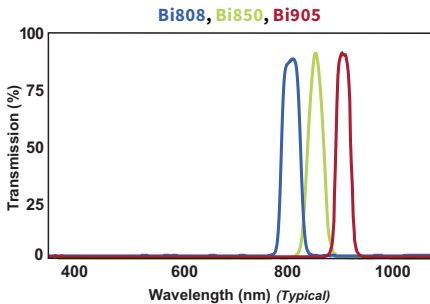
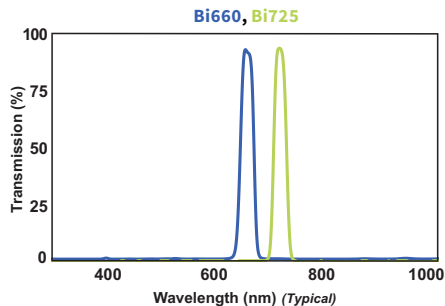
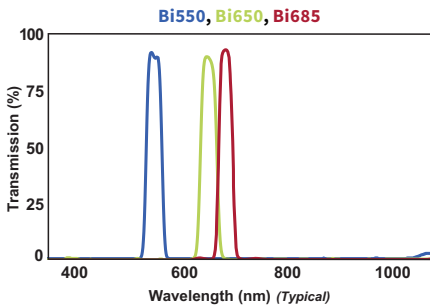
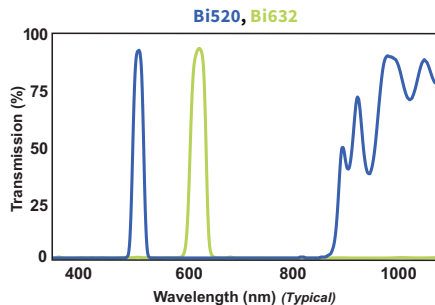
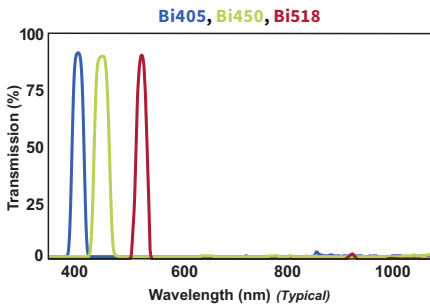

MULTI-BANDPASS FILTERS

DUAL BANDPASS / TRIPLE BANDPASS

Commonly used for Normalized Difference Vegetation Index (NDVI) imaging and Enhanced Normalized Difference Vegetation Index (ENDVI) imaging.

- Eliminate the need for dual or tri sensor imaging
- Anti-reflection coated for maximum transmission
- Hard-coated, single-substrate fabrication
- Pass red or blue visible light, while simultaneously passing green and NIR light
- Ideal when working with indices such as CV, NG, and ENDVI used to monitor crop health
- Recommended for installation behind the camera lens, requiring exceptional surface quality; 10/5 scratch/dig

APPLICATIONS: Multi-Bandpass Filters have become popular in NDVI aerial drone inspection, allowing for single sensor imaging and reduced operational payload. NDVI calculation, traditionally achieved through satellite imagery, can now be obtained by utilizing Multi-Bandpass Filters and personal aerial imaging devices.

CONCEPT: Plants reflect different wavelengths of light to varying degrees based on their health. A healthy leaf absorbs blue and red light for photosynthesis, while it reflects some green light and strongly reflects near-infrared (NIR) light. Stressed vegetation reflects greater amounts of red, blue and green light while reflecting for NIR light.

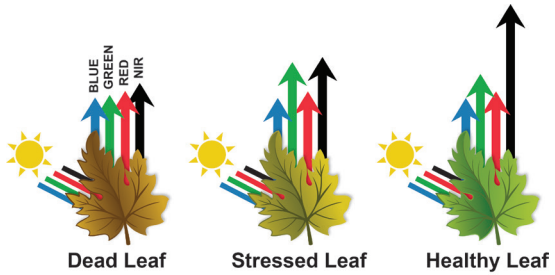

MOUNT & SIZE OPTIONS: Multi-Bandpass Filters are offered in various standard threaded mounts custom mounts, sizes cut to fit the front or back of any lens, or the front of the camera sensor. Standard material thicknesses include 0.5mm, 1.1mm and 2.0mm.

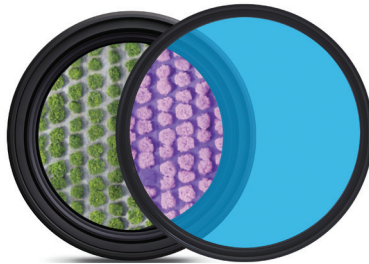

For more information, visit [midopt.com/multi-bandpass](https://www.midopt.com/multi-bandpass)

FILTERS & TRANSMISSION CURVES

DUAL BANDPASS FILTERS

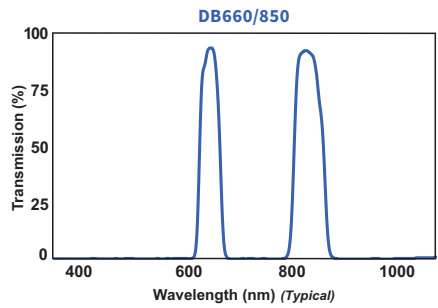
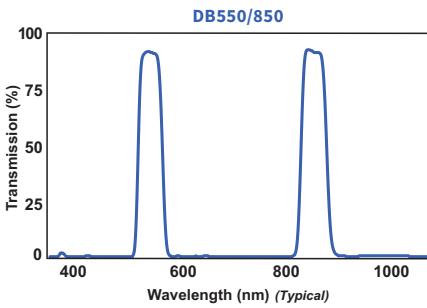
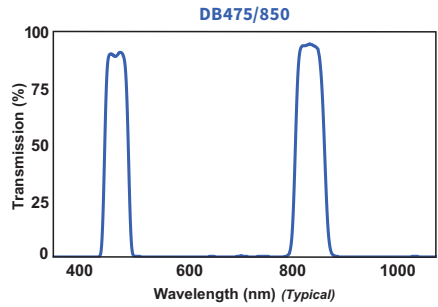
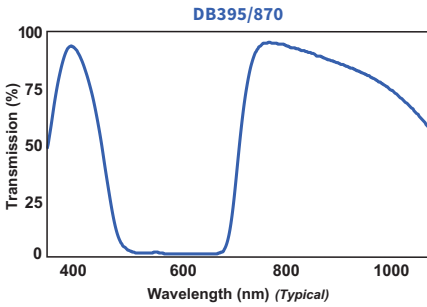

TRIPLE BANDPASS FILTERS

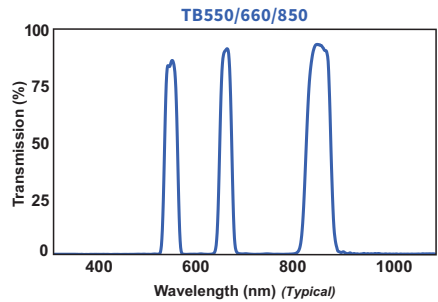
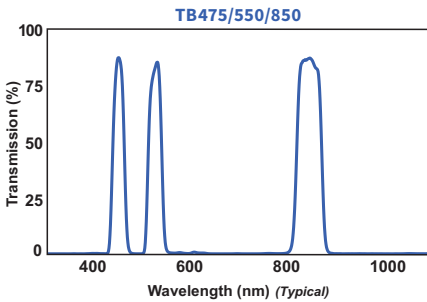

Multi-Bandpass
DB
TB

DUAL BANDPASS FILTERS

FOR DAY AND NIGHT

Dual Bandpass Filters are single filters that work twice as hard. They're ideal for applications using a color camera that require accurate color imaging during the day and infrared imaging at night.

- Pass visible light and a specific portion of the VIS and NIR spectrums
- Ideal for color camera applications that utilize daytime sunlight and NIR illumination at night
- Eliminate the need for dual sensor imaging
- Achieve accurate color rendition by blocking interfering (NIR) wavelengths
- Anti-reflection coated for maximum transmission
- Hard-coated, single-substrate fabrication
- Exceptional surface quality; 40/20 scratch/dig

APPLICATIONS: Most commonly used for security and surveillance and Intelligent Transportation Systems (ITS). One Dual Bandpass Filter can completely eliminate the need for a costly switching mechanism or expensive two-camera system.

MOUNT & SIZE OPTIONS: Dual Bandpass Filters are in stock, ready to ship, and are available in Threaded Mounts, sizes M13.25 to M82; 25.4° C-Mounts; Slip Mounts; or Unmounted. Dual Bandpass Filters can be optically cemented behind an M12 lens if preferred. Custom shapes and sizes are also available.



For more information, visit midopt.com/multi-bandpass

FILTERS & TRANSMISSION CURVES

DUAL BANDPASS FILTERS

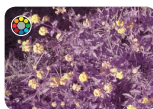
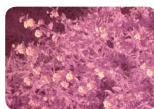
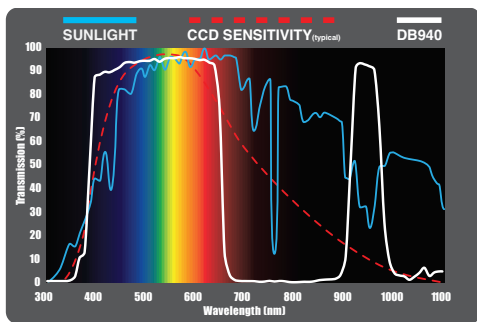
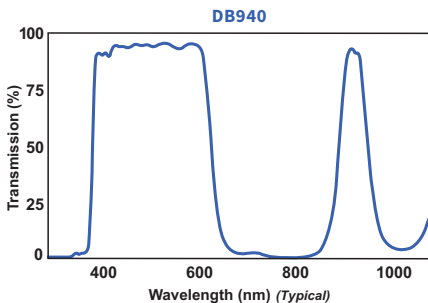
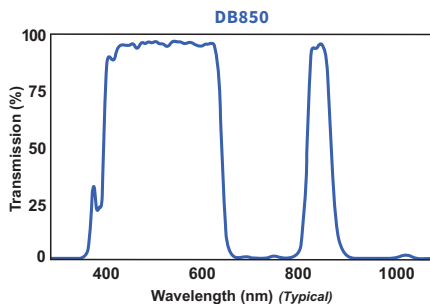
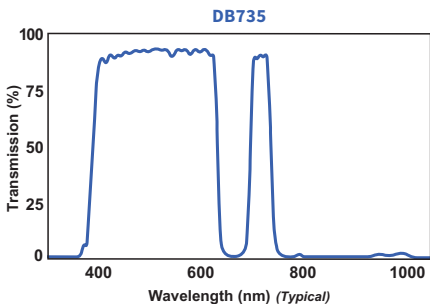

Sunlight contains an almost overwhelming amount of infrared light; however, output in the region around 940nm is not as significant. Using a DB940 Filter takes advantage of this feature, resulting in greatly improved color rendition compared to Visible/850nm Dual Band Filters.

Often referred to as “sharp-cut” filters, Longpass Filters are specially designed to pass a broad spectrum of longer wavelength light while blocking shorter wavelengths.

- Economical solution for isolating specific spectral regions
- Peak transmission $\geq 90\%$
- StableEDGE® design reduces angular dependence and minimizes short-shifting effects
- Anti-reflection coated for maximum transmission in VIS — SWIR spectrums
- Can be used with Shortpass Filters for a custom, fine-tuned Bandpass Filter
- Double-side polished glass for exceptional parallelism and optical flatness
- Exceptional surface quality; 40/20 scratch/dig
- Available in wavelength ranges from 350-12 microns

APPLICATIONS: Longpass Filters are often used in fluorescence applications to block an excitation light source or to pass multiple emission wavelengths, improving signal to noise ratio in light-controlled environments. Longpass Filters are also commonly used in photography and astronomy.

MOUNT & SIZE OPTIONS: Longpass Filters are in stock, ready to ship, and are available in Threaded Mounts, sizes M13.25 to M105; 25.4® C-Mounts; Slip Mounts; or Unmounted. Custom shapes and sizes are also available.



For more information, visit midopt.com/longpass

FILTERS & TRANSMISSION CURVES

LONGPASS FILTERS

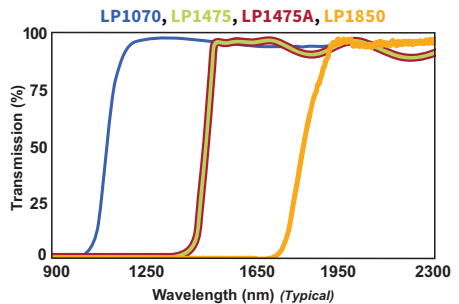
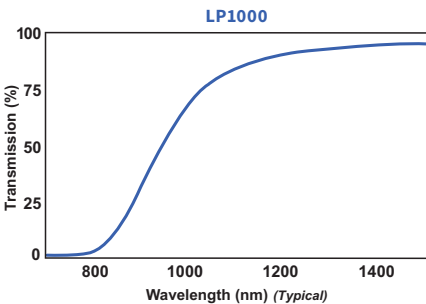
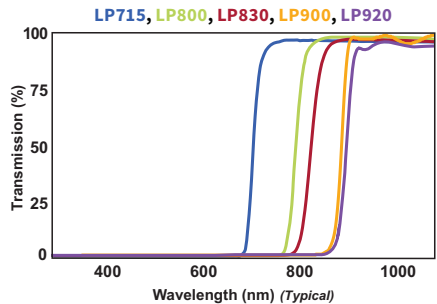
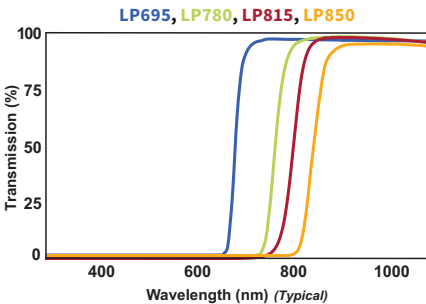
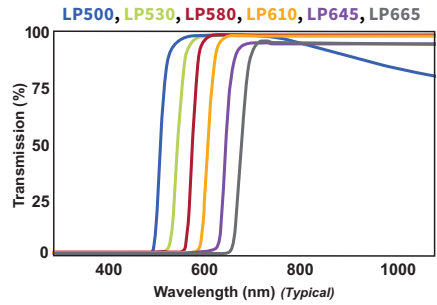
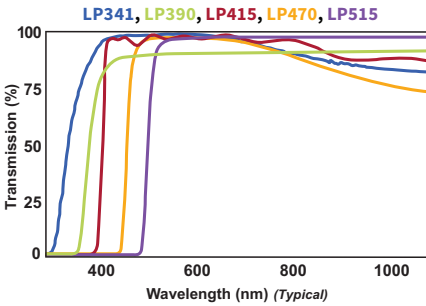
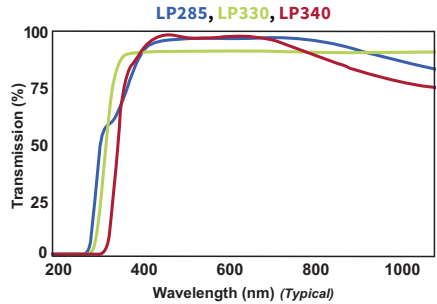
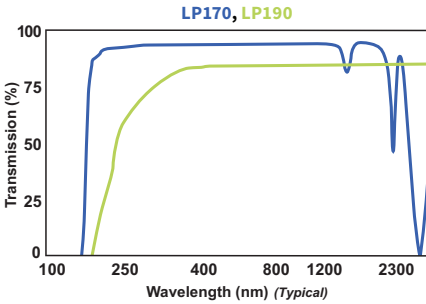

SHORTPASS / NIR-CUT FILTERS

Often thought of as “IR-cut” Filters, Shortpass Filters are specifically designed to pass a broad spectrum of shorter wavelength light, while blocking longer VIS and NIR wavelengths.

- Peak transmission $\geq 90\%$
- Anti-reflection coated for maximum transmission
- Can be used with Longpass Filters for a custom, fine-tuned Bandpass Filter
- Exceptional surface quality; 10/5 scratch/dig* for over the sensor
- Precision polished glass substrate
- Available in wavelength ranges from 340-785 nm

**Applies in most cases*

SP SERIES - VIS PASS

- Separate color in monochrome or color applications
- Improve contrast and resolution

SP SERIES - NEAR-IR BLOCK

- Commonly placed over the camera's image sensor to block near-IR light and achieve natural color rendition
- Used as a hot mirror to reduce unwanted heat build-up caused by infrared radiation

APPLICATIONS: Shortpass Filters are commonly used in color imaging to achieve natural color rendering. They can also be used to protect the sensor from NIR laser damage or to reduce IR radiation or “camera bloom” created during hot metal or glass extrusion processes.

MOUNT & SIZE OPTIONS: Shortpass Filters are in stock, ready to ship, and are available in Threaded Mounts, sizes M13.25 to M105; 25.4[®] C-Mounts; Slip Mounts; or Unmounted. Shortpass Filters can be optically cemented behind an M12 lens if preferred. Custom shapes and sizes are also available.



For more information, visit midopt.com/shortpass

FILTERS & TRANSMISSION CURVES

SP SERIES: VIS PASS

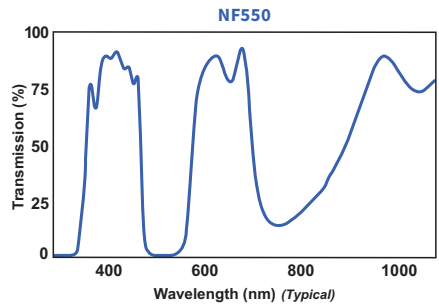
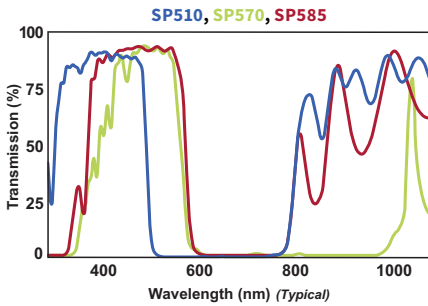

SP SERIES: VIS PASS / NIR BLOCK

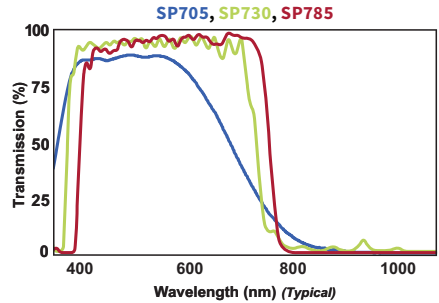
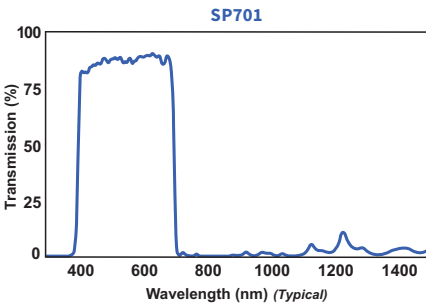
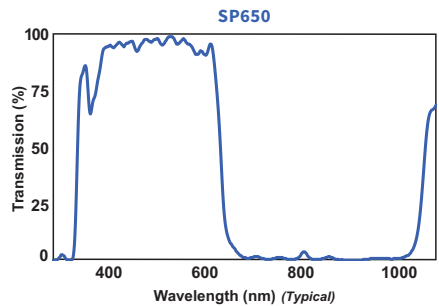
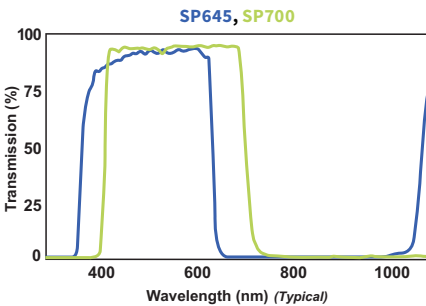
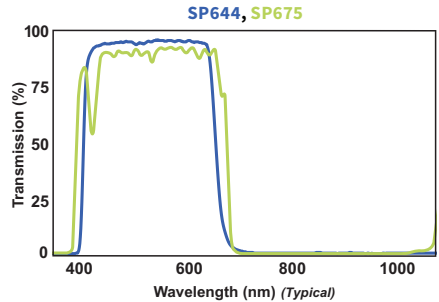
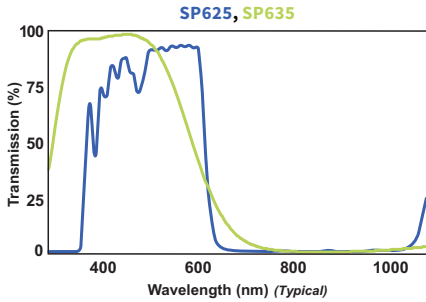

POLARIZERS

Polarizing Filters reduce reflection, enhance contrast and detect imperfections in transparent materials. Polarizing Filters for the camera lens should be used in combination with Polarizing Film for the light source to maximize glare reduction and achieve the best results.

POLARIZING FILTERS

MidOpt rotating Linear Polarizers thread onto the lens. Rotating the mount and visually observing the results makes it easy to determine the position at which glare reduction is maximized. All mounted MidOpt polarizers come with a locking thumbscrew to ensure that jarring or accidental movement during cleaning does not result in a change to the filter's position.



- Contrast ratios of up to 10,000:1
- Linear, circular and wire grid polarizers are available for VIS — SWIR spectrums
- Rotating mount with locking thumb screw to fine tune glare reduction
- Available with anti-reflection and oleophobic coatings
- Exceptional surface quality; 40/20 scratch/dig*

**Applies in most cases*

POLARIZING FILM

To maximize extinction, Linear Polarizers should be placed over the system's light source(s) to decrease glare and to help block incident light.

- Achieves optimal glare reduction when placed over light source
- Contrast ratios of up to 10,000:1
- Offered in high-temperature-resistant laminate and glass
- Linear polarizers are available for VIS and near-IR requirements
- Left and right circular polarizers are available for VIS spectrum applications
- PSA007, HTA008 and PSA1000 material comes standard with self-adhesive backing

APPLICATIONS: Polarizers are commonly used to reduce glare from objects with smooth surfaces or surfaces covered with grease, oil or liquid, and to detect stress and imperfections in transparent material.



For more information, visit [midopt.com/polarizing](https://www.midopt.com/polarizing)

POLARIZERS

MOUNT & SIZE OPTIONS: Polarizing Filters and Films are in stock, ready to ship, and are available in Threaded Mounts, sizes M22.5 to M105; Slip Mounts; or Unmounted. Polarizing Film is available in multiple thicknesses and can be custom laser cut to fit any light source with a maximum usable width of 16.5" and length up to 300'.

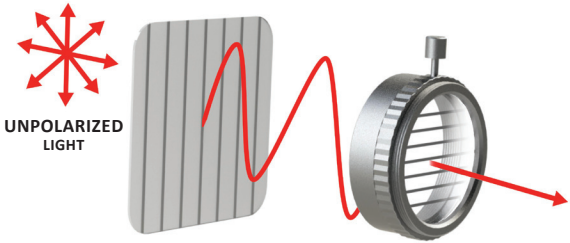

LINEAR POLARIZING FILM
(FOR LIGHT SOURCE)

LINEAR POLARIZING FILTER
(FOR LENS) Rotate perpendicular to the axis of polarization of the Linear Polarizing Film for maximum glare reduction.

POLARIZING FILTERS

PART #	USEFUL RANGE (nm)	CONTRAST RATIO
PR032	400-700	Up to 3000:1
PR120	400-700	Up to 10,000:1
PC052	400-700	Up to 700:1
PR1000	400-2000	Up to 8000:1

See page 39 for more details

POLARIZING FILMS

PART #	USEFUL RANGE (nm)	CONTRAST RATIO
PS007	400-700	Up to 3000:1
PSA007	400-700	Up to 3000:1
PS010	400-700	Up to 3000:1
PS030	400-700	Up to 7000:1
HT025	400-700	Up to 5000:1
HT008	400-700	Up to 10,000:1
HTA008	400-700	Up to 10,000:1
PG120	400-700	Up to 10,000:1
PS1000	400-2000	Up to 8000:1
PSA1000	400-2000	Up to 8000:1
PG1000	400-2000	Up to 8000:1

Pi1000 DETAILED DESIGN

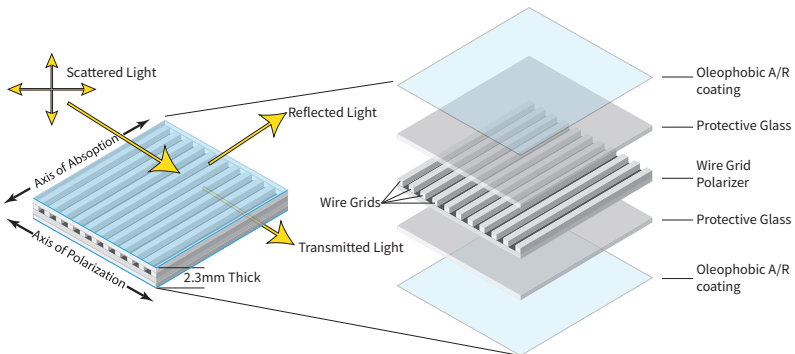

NEUTRAL DENSITY FILTERS

Neutral Density Filters are designed to reduce light intensity neutrally over a specific wavelength range without affecting image color or contrast. They serve as "sunglasses" for your system and can be used with monochrome or color cameras.

- Available in a variety of optical densities
- Reduce light intensity while maintaining a wide aperture and shallow depth of field
- Minimize pixel saturation
- Can be stacked with other Neutral Density Filters to achieve custom optical densities
- Exceptional surface quality; 40/20 scratch/dig

ND SERIES

VISIBLE (VIS) SPECTRUM

- Absorptive filter effective from 425-675nm
- Available in optical densities ranging from 0.10-6.0

Ni SERIES

BROAD SPECTRUM; VIS/SWIR

- Low reflectivity filter effective from 400-2000nm
- Available in optical densities ranging from 0.3-2.0
- Coated on low-expansion, heat-resistant Borofloat® glass

APPLICATIONS: Applications include imaging in intense lighting situations (i.e. molten metal and welding), outdoor aerial imaging and photography. Neutral Density Filters help reduce shutter speed to create blur, preventing a “jello” effect in aerial imaging.

MOUNT & SIZE OPTIONS: Neutral Density Filters are in stock, ready to ship, and are available in Threaded Mounts, sizes M13.25 to M105; 25.4® C-Mounts; Slip Mounts; or Unmounted. Custom shapes and sizes are also available.

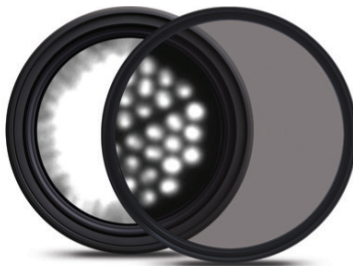

For more information, visit midopt.com/neutral-density

FILTERS & TRANSMISSION CURVES

ND SERIES: VIS

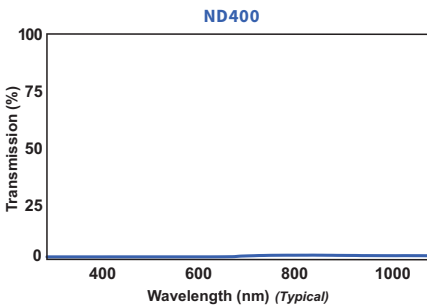
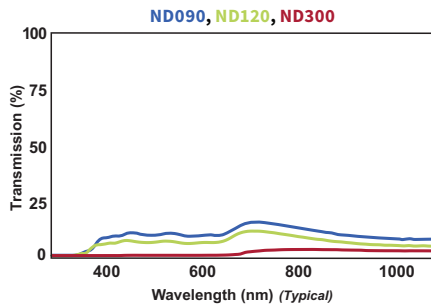
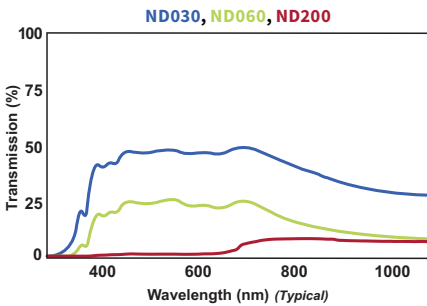

Ni SERIES: VIS-NIR

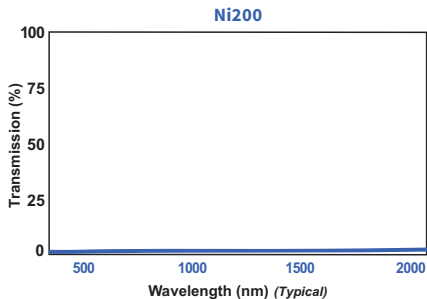
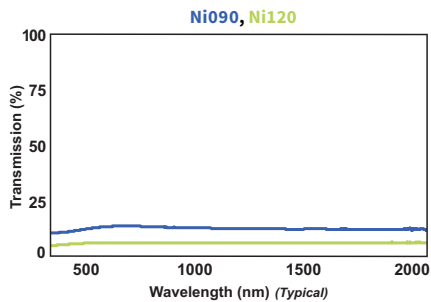
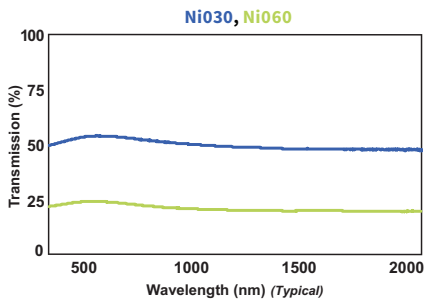

LIGHT BALANCING FILTERS

Light Balancing Filters correct artificial lighting so colors appear more natural. These filters balance color, preventing the need for additional software processing. This allows for greater image stability and control.

- Achieve accurate color images when using an artificial light source
- Increase contrast by correcting the emission spectrum of various lighting sources
- Exceptional surface quality; 40/20 scratch/dig

LA SERIES: Reduce blue shading ("warm" the scene). Commonly used with white LED and xenon strobe lighting.

LB SERIES: Subdue the reddish hue sometimes found with tungsten, halogen, sodium and other light sources.

FL SERIES: Used to reduce the greenish cast created by fluorescent lighting.

APPLICATIONS: Light Balancing Filters are commonly used in color applications to create natural light (i.e. machine vision/factory automation, photography, progressive photonics and fluorescence imaging) where accurate color inspection is needed.

MOUNT & SIZE OPTIONS: Light Balancing Filters are in stock, ready to ship, and are available in Threaded Mounts, sizes M13.25 to M105; Slip Mounts; or Unmounted. Custom shapes and sizes are also available.

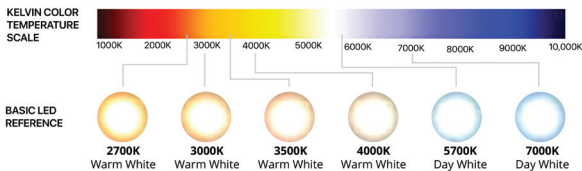

The tint of white depends on the color temperature of the light. When color temperature is high, more blue light exists.

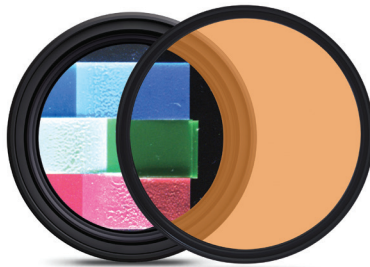

For more information, visit midopt.com/light-balancing

FILTERS & TRANSMISSION CURVES

LA SERIES

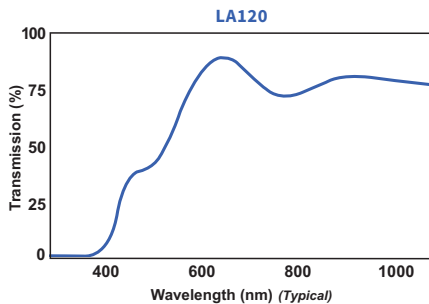
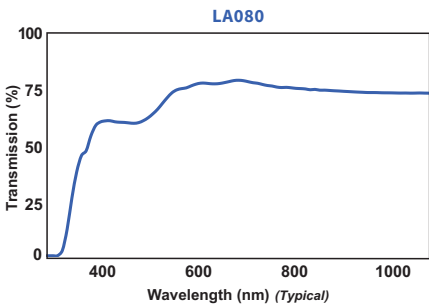

LB SERIES

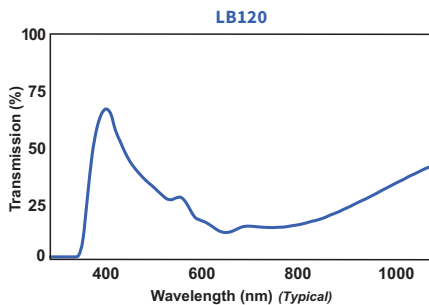
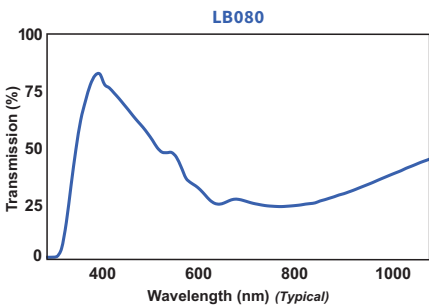

FL SERIES

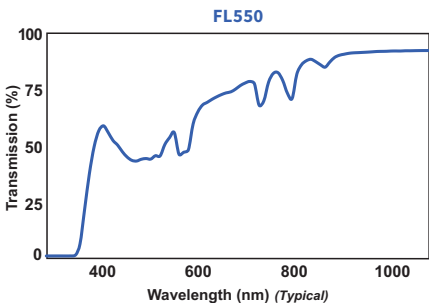

Acrylic Filters are durable and lightweight, and are an economical solution for inspection windows. They can protect lenses in environments where broken glass might pose a problem.

- High transmission ranging from 90-98%
- Offered in anti-reflection, oleophobic and hard coatings for transmission and durability
- Optical-grade acrylic
- Impact-resistant
- Half the weight of glass

APPLICATIONS: Acrylic Filters are frequently used for lens protection and economical enclosure windows, as well as over lighting to control the wavelength emission of broad spectrum light sources. They are common in Food & Drug Administration (FDA) and European Food Safety Authority (EFSA) inspection applications where glass over the inspection area is not permitted.

MOUNT & SIZE OPTIONS: Acrylic Filters are in stock, ready to ship, and are available in Threaded Mounts, sizes M13.25 to M105 and in Slip Mounts. Acrylic Filters can be precision laser-cut to a desired size or configuration and are available for next day delivery.



For more information, visit midopt.com/acrylic

FILTERS & TRANSMISSION CURVES

AB SERIES: ACRYLIC BANDPASS

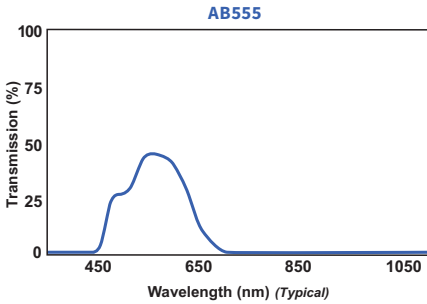

AC SERIES: ACRYLIC LONGPASS

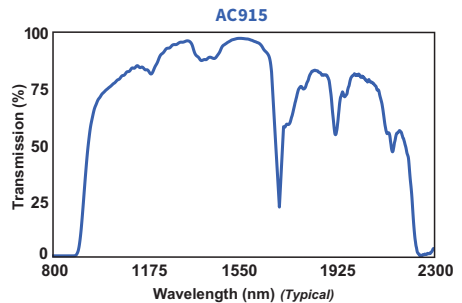
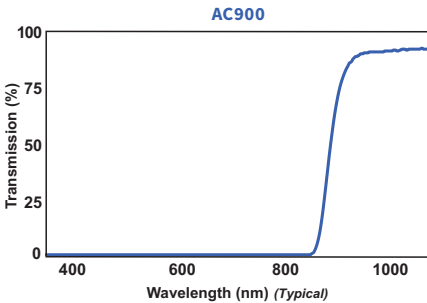
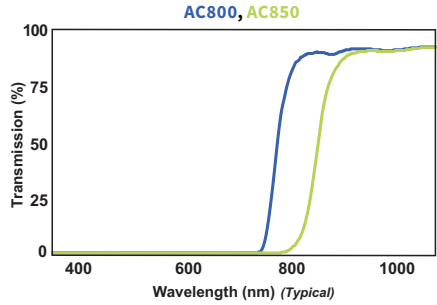
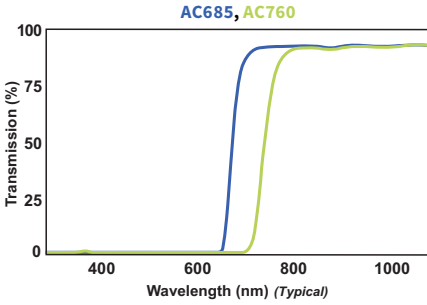
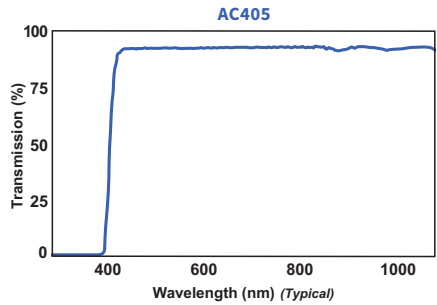
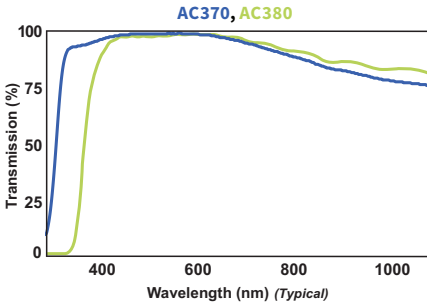

PROTECTIVE FILTERS

Protective Filters are designed to shield lenses and lighting from dirt, dust, liquids, impact and harsh environments, without sacrificing image quality.

- Economical solution to protect expensive lenses
- Useful for imaging in UV, VIS and NIR spectrums
- Available with a high-efficiency, anti-reflection coating to maximize transmission to 98% or more
- Offered in both glass and acrylic
- Exceptional surface quality; 40/20 scratch/dig*

APPLICATIONS: Protective Filters are useful in all imaging applications. The LP285 can withstand high temperatures and is impact resistant (similar qualities to Pyrex).

MOUNT & SIZE OPTIONS: Polarizer Filters are in stock, ready to ship, and are available in Threaded Mounts, sizes M13.25 to M105; 25.4° C-Mount; Slip Mounts; or Unmounted. Custom shapes and sizes are also available.

*Applies in most cases

PART#	DESCRIPTION	USEFUL RANGE (nm)	CUT-ON WL 50% T	PEAK TRANSMISSION	SE ✓
LP SERIES – LENS PROTECTION					
○ LP170	Fused Silica Protective Window	200-2300nm	170nm	≥94%	•
○ LP190	Sapphire Protective Window	250-2300nm	190nm	≥88%	•
○ LP285	Borofloat Heat Resistant VIS-NIR A/R Protective Window	350-1100nm	285nm	≥98%	•
○ LP330	Glass Protective Window	350-1100nm	330nm	≥90%	•
○ LP340	A/R Glass Protective Window	350-800nm	340nm	≥98%	•
○ LP341	Oleophobic A/R Protective Window	350-800nm	340nm	≥98%	•
○ LP390	UV Absorbing Protective Window	410-1100nm	390nm	≥90%	•
○ LP415	UV-Block A/R Protective Window	415-1100nm	415nm	≥95%	•
○ AC370	A/R Acrylic Protective Window	380-850nm	370nm	≥98%	•
○ AC380	A/R Acrylic Protective Window	450-850nm	380nm	≥95%	•
○ AC405	UV Block Acrylic Protective Window	415-1100nm	405nm	≥90%	•



For more information, visit midopt.com/protective

MOUNTING SOLUTIONS



THREADED MOUNT

Designed for lenses with filter threads.

CREATE PART #: Select a filter, use "M" for mount and add a mount size (e.g. M27)

Example: BP470-27



25.4[®] C-MOUNT

Threads directly into any C-mount camera between the lens and sensor.

CREATE PART #: Select a filter, and add "-25.4"

Example: BP470-25.4



SLIP MOUNT

Designed for wide-angle lenses without filter threads.

CREATE PART #: Select a filter, use "S" for slip and add the outside diameter of the lens in millimeters. (e.g. S43mm)

Example: BP470-S43



SOLUTIONS FOR M12 LENSES

Offered in aluminum slip mount over the lens.

CREATE PART #: Select a filter, use "S" for slip and add the outside diameter of the lens in millimeters followed by the letter "A". (e.g. S14mmA)

Example: BP470-S14A

UNMOUNTED

Designed for wide-angle lenses without filter threads.

CREATE PART #:

CIRCLE:

Use "D" and add diameter in mm

Example: BP470-D19

SQUARE:

Use "R" and add side measurement in mm

Example: BP470-R15

RECTANGLE:

Use "R" and add length in mm x width in mm.

Example: BP470-R30x15

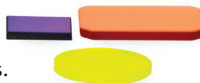

For more information, visit midopt.com/mounts

+ THREADED

Mount Size	Pitch
M13.25	0.5
M22.5	0.5
M25.5	0.5
M27	0.5
M30.5	0.5
M34	0.5
M35.5	0.5
M37	0.75
M37.5	0.5
M39	0.5
M40.5	0.5
M43	0.75
M46	0.75
M48	0.75
M49	0.75
M52	0.75
M55	0.75
M58	0.75
M62	0.75
M67	0.75
M72	0.75
M77	0.75
M82	0.75
M86	1.0
M95	1.0
M105	1.0

+ C-MOUNT

M25.4[™]

+ SLIP MOUNT

Outside Dia. Range	Threaded Mount
15.1-19.0	M22.5
19.1-26.5	M30.5
26.6-31.9	M40.5
32.0-40.9	M46
41.0-50.9	M55
51.0-57.9	M62
58.0-68.0	M72
68.1-79.0	M82
79.1-101.0	M105

+ M12 MOUNT

Outside Dia. Range	Part #
13.2-14.2	S14A
14.3-15.0	S15A

+ UNMOUNTED

Custom Shapes & Sizes Available

FILTER KITS



**FK200 MACHINE
VISION FILTER KIT**



**FK220 BN SERIES
FILTER TEST KIT**



**FS100 MACHINE VISION
FILTER SWATCH KIT**



**NS100 NEUTRAL DENSITY FILTER
SWATCH KIT**



**SK100 SUPER FILTER
TEST KIT**
INCLUDES 70 FILTERS FOR UV,
VISIBLE AND NEAR-IR IMAGING



**FK100 MACHINE VISION
FILTER BINDER KIT**
FOR SIZES M22 TO M105



**IK100 NEAR-INFRARED
FILTER BINDER KIT**
FOR SIZES M22 TO M105



**NK100 NEUTRAL DENSITY
FILTER BINDER KIT**
FOR SIZES M22 TO M105

For more information, visit midopt.com/filter-kits

ACCESSORIES & OPTICS



EXTENSION RINGS



ROTATING RIGHT ANGLE ATTACHMENTS



STEP ADAPTER RINGS



CLOSE-UP LENS SET



LENS ENCLOSURES



CLEANING KITS



CUSTOM LENSES



WINDOWS



MIRRORS



PRISMS



WEDGES



LIGHT PIPES



DIFFUSERS



BEAMSPLITTERS

T/R	Thickness
50:50	0.5-3.0 mm
70:30	1.0-2.0 mm
30:70	1.0-2.0 mm
80:20	1.0-2.0 mm
20:80	1.0-2.0 mm



TEST GLASS RENTAL

MidOpt has more than 3,000 test glass radii in house, contact us for more information.

For more information, visit midopt.com/accessories | midopt.com/custom-optics

FILTER LINE-UP

KEY FEATURES



StableEDGE® Technology
Gaussian Design



Anti-Reflection Coated
40/20 Scratch/Dig

PART #	DESCRIPTION	USEFUL RANGE (nm)				
--------	-------------	-------------------	--	--	--	--

BANDPASS | BP Series: Broad Bandwidth

● BP250	Deep-to-Near UV Bandpass	230-275		●		*
● BP324	Near-UV Bandpass	290-365	●	●	●	●
● BP365	Near-UV Bandpass	335-400		●	●	●
● BP470	Blue Bandpass	425-495	●	●	●	●
● BP485	Absorptive VIS Bandpass/NIR Block	380-585	●	●	●	●
● BP500	Green-Blue Bandpass	440-555	●	●	●	●
● BP505	Cyan Bandpass	485-550	●	●	●	●
● BP525	Light Green Bandpass	500-555	●	●	●	●
○ PE530	Photopic Response Filter	495-565		●	●	●
○ BP550	NIR/UV Block-Visible Bandpass	405-690			●	●
● BP590	Orange Bandpass	560-600	●	●	●	●
● BP635	Light Red Bandpass	615-645	●	●	●	●
● BP660	Dark Red Bandpass	640-680	●	●	●	●
● BP695	Near-IR Bandpass	680-720	●	●	●	●
● BP735	Near-IR Bandpass	715-780	●	●	●	●
● BP800	Near-IR Bandpass	745-950	●	●	●	●
● BP850	Near-IR Bandpass	820-910	●	●	●	●
● BP880	Near-IR Bandpass	845-930	●	●	●	●

* 60/40 Scratch/dig surface quality

BANDPASS | BN Series: Narrow Bandwidth

● BN470	Narrow Blue Bandpass	460-490	●	●	●	●
● BN520	Narrow Green Bandpass	510-545	●	●	●	●
● BN532	Narrow Green Bandpass	525-550	●	●	●	●
● BN535	Narrow Green Bandpass	520-545	●	●	●	●
● BN595	Narrow Orange Bandpass	580-610	●	●	●	●
● BN630	Narrow Light Red Bandpass	625-645	●	●	●	●
● BN650	Narrow Dark Red Bandpass	638-672	●	●	●	●
● BN660	Narrow Dark Red Bandpass	645-675	●	●	●	●
● BN740	Narrow Near-IR Bandpass	730-755	●	●	●	●
● BN785	Narrow Near-IR Bandpass	770-790	●	●	●	●
● BN810	Narrow Near-IR Bandpass	798-820	●	●	●	●
● BN850	Narrow Near-IR Bandpass	840-865	●	●	●	●
● BN880	Narrow Near-IR Bandpass	855-890	●	●	●	●
● BN940	SWIR Bandpass	928-955	●	●	●	●

BANDPASS | Bi Series: Narrow Interference

● Bi405	Violet Interference Bandpass	400-415		●		●
● Bi450	Blue Interference Bandpass	445-465		●		●
● Bi518	(Limited) Light Green Interference Bandpass	510-525		●		●
● Bi520	Light Green Interference Bandpass	515-525		●		●
● Bi550	Green Interference Bandpass	535-558		●		●
● Bi632	Light Red Interference Bandpass	625-640		●		●
● Bi650	Red Interference Bandpass	643-665		●		●
● Bi660	Dark Red Interference Bandpass	650-665		●		●
● Bi685	Dark Red Interference Bandpass	675-692		●		●
● Bi725	Red Edge Bandpass	717-732		●		●
● Bi808	Near-IR Interference Bandpass	798-820		●		●
● Bi850	Near-IR Interference Bandpass	845-860		●		●
● Bi905	Near-IR Interference Bandpass	895-915		●		●

BANDPASS | SWIR: Short-Wave Infrared

● BP1000	SWIR Bandpass	930-1030	●	●	●	●
● BP1550	SWIR Bandpass	1485-1645	●	●	●	●
● Bi1300	SWIR Interference Bandpass	1290-1310		●	●	●
● Bi1450	SWIR Interference Bandpass	1440-1460		●	●	●
● Bi1550	SWIR Interference Bandpass	1540-1560		●	●	●

PART #	DESCRIPTION	USEFUL RANGE (nm)	SE ✓	Λ	A/R	40/20
--------	-------------	-------------------	------	---	-----	-------

DUAL BANDPASS | DB Series: Dual Bandwidth

DB395/870	Absorptive VIS + NIR	375-425, 745-970	•		•	•
DB475/850	Blue + 850nm NIR	460-490, 830-870		•		•
DB550/850	Green + 850nm NIR	535-565, 830-870		•		•
DB660/850	Red + 850nm NIR	645-675, 830-870		•		•
DB735	Visible + 735nm NIR	405-645, 725-755				•
DB850	Visible + 850nm NIR	405-645, 835-875				•
DB940	Visible + 940nm NIR	405-650, 925-965				•

TRIPLE BANDPASS | TB Series: Triple Bandwidth

TB475/550/850	Blue + Green + NIR	468-483, 543-558, 835-865		•	•	•
TB550/660/850	Green + Red + NIR	543-558, 653-668, 835-865		•	•	•

LONGPASS | LP Series: Longpass

LP170	Fused Silica Protective Window	200-2300	•			•
LP190	Sapphire Protective Window	250-2300	•			•
LP285	Borofloat Heat Resistant VIS-NIR A/R Protective Window	350-1100	•		•	•
LP330	Glass Protective Window	350-1100	•			•
LP340	A/R Glass Protective Window	350-800	•		•	•
LP341	Oleophobic A/R Coating Protective Window	365-1100	•		†	•
LP390	UV Absorbing Protective Window	410-1100	•			•
LP415	UV Block	415-1100			•	•
LP470	Light Yellow Longpass	480-1100	•		•	•
LP500	Yellow Longpass	510-1100	•		•	•
LP515	Yellow-Orange Longpass	520-1100	•		•	•
LP530	Orange Longpass	545-1100	•		•	•
LP550	Orange Longpass	560-1100	•		•	•
LP580	Red-Orange Longpass	585-1100	•		•	•
LP590	Red Longpass	605-1100	•		•	•
LP610	Red Longpass	620-1100	•		•	•
LP630	Red Longpass	645-1100	•		•	•
LP645	Dark Red Longpass	650-1100	•		•	•
LP665	Dark Red Longpass	680-1100	•		•	•
LP695	Near-IR Longpass	715-1100	•		•	•
LP715	Near-IR Longpass	730-1100	•		•	•
LP780	Near-IR Longpass	800-1100	•		•	•
LP800	Near-IR Longpass	820-1100	•		•	•
LP815	Near-IR Longpass	825-1100	•		•	•
LP830	Near-IR Longpass	845-1100	•		•	•
LP850	Near-IR Longpass	870-1100	•		•	•
LP900	SWIR Longpass	910-1100	•		•	•
LP920	SWIR Longpass	930-2300			•	•
LP1000	SWIR Longpass	1010-2300	•		•	•
LP1070	SWIR Longpass	1100-2300	•		•	•
LP1475	SWIR Longpass	1490-2300			•	•
LP1475A	SWIR Longpass / Extended VIS Block	1490-2300			•	•
LP1850	SWIR Longpass	1900-12,000	•		•	•

† Oleophobic AR Coating

FILTER LINE-UP

PART #	DESCRIPTION	USEFUL RANGE (nm)	SE	W	A/R	40/20
--------	-------------	-------------------	----	---	-----	-------

SHORTPASS | SP Series: VIS Pass

SP510	Blue Shortpass	340-500			•	•
SP570	Blue-Green Shortpass	410-560			•	•
SP585	Cyan Shortpass	395-575			•	•
NF550	Magenta Dichroic (Green Block)	395-475, 605-700			•	•

SHORTPASS | SP Series: VIS Pass / NIR Block

SP625	Blue-Orange Shortpass	425-620	•		•	•
SP635	Absorptive VIS Shortpass/NIR Block	380-585	•		•	•
SP644	Near-IR/Mid-Red Dichroic Block	395-638			•	•
SP645	Near-IR/Mid-Red Dichroic Block	400-640			•	•
SP650	Near-IR/Mid-Red Dichroic Block	400-640			•	•
SP675	Near-IR/Deep Red Dichroic Block	420-660			•	•
SP700	Near-IR/UV Block-Visible Shortpass	405-690			•	•
SP701	Extended Hot Mirror	410-690			•	★
SP705	Near-IR/Deep Red Absorp. Block	370-630	•		•	•
SP730	Near-IR/Colorless Dichroic Block	400-710			•	•
SP785	Modified Near-IR Dichroic Block	425-770	•		•	•

★ 60/40 Scratch/dig surface quality

NEUTRAL DENSITY | ND Series: VIS

ND030	Absorptive 50% Transmission	425-675	•			•
ND060	Absorptive 25% Transmission	425-675	•			•
ND090	Absorptive 12.5% Transmission	425-675	•			•
ND120	Absorptive 6.25% Transmission	425-675	•			•
ND200	Absorptive 1.0% Transmission	425-675	•			•
ND300	Absorptive 0.1% Transmission	425-675	•			•
ND400	Absorptive 0.01% Transmission	425-675	•			•

NEUTRAL DENSITY | Ni Series: VIS-NIR

Ni030	Low Reflectivity 50% Transmission	400-2000			•	•
Ni060	Low Reflectivity 25% Transmission	400-2000			•	•
Ni090	Low Reflectivity 12.5% Transmission	400-2000			•	•
Ni120	Low Reflectivity 6.25% Transmission	400-2000			•	•
Ni200	Reflective 1% Transmission	400-2000			•	•

PROTECTIVE | LP Series: Lens Protection

AC370	A/R Acrylic Protective Window	380-850	•		†	★
AC380	A/R Acrylic Protective Window	450-850	•		•	★
AC405	UV Block Acrylic Protective Window	415-1100	•			★
LP170	Fused Silica Protective Window	200-2300	•			•
LP190	Sapphire Protective Window	250-2300	•			•
LP285	Borofloat Heat Resistant	350-1100	•		•	•
LP330	VIS-NIR A/R Protective Window	350-1100	•			•
LP340	Glass Protective Window	350-1100	•			•
LP340	A/R Glass Protective Window	350-800	•		•	•
LP341	Oleophobic A/R Protective Window	365-1100	•		†	•
LP390	UV Absorbing Protective Window	410-1100	•			•
LP415	UV Block	415-1100			•	•

★ 80/50 Scratch/dig surface quality † Oleophobic AR Coating

LIGHT BALANCING

LA080	Light Balancing (Minus Blue)	400-700	•			•
LA120	Light Balancing (Minus Blue)	400-700	•		•	•
LB080	Light Balancing (Minus Red)	400-700	•			•
LB120	Light Balancing (Minus Red)	400-700	•			•
FL550	Light Balancing (Minus Green)	400-700	•			•

PART #	DESCRIPTION	USEFUL RANGE (nm)	SE	W	A/R	80/50
--------	-------------	-------------------	----	---	-----	-------

ACRYLIC | AB Series: Acrylic Bandpass

● AB555	Acrylic Absorptive NIR/UV-Block Visible Bandpass	470-645	●	●		●
----------------	--	---------	---	---	--	---

ACRYLIC | AC Series: Acrylic Longpass

○ AC370	A/R Acrylic Protective Window	380-850	●		†	●
○ AC380	A/R Acrylic Protective Window	450-850	●	●		●
○ AC405	UV Block Acrylic Protective Window	415-1100	●			●
● AC685	Acrylic Near-IR Longpass	710-1100	●			●
● AC760	Acrylic Near-IR Longpass	780-1100	●			●
● AC800	Acrylic Near-IR Longpass	815-1100	●			●
● AC850	Acrylic Near-IR Longpass	880-1100	●			●
● AC900	Acrylic SWIR Longpass	930-1650	●			●
● AC915	Acrylic SWIR Longpass	960-1650; 1750-1890; 1925-2090	●		●	●

† Oleophobic AR Coating

PART #	DESCRIPTION	USEFUL RANGE (nm)	CONTRAST RATIO	A/R	40/20
--------	-------------	-------------------	----------------	-----	-------

POLARIZING FILTERS

● PR032	Linear Polarizer	400-700	Up to 3000:1		●
● PR120	Ultra High Contrast Linear Polarizer	400-700	Up to 10,000:1	†	★
● PC052	Circular Polarizer	400-700	Up to 700:1		●
● PR1000	VIS-NIR Wire Grid Linear Polarizer	400-2000	Up to 8000:1	†	★

★ 60/40 Scratch/dig surface quality † Oleophobic AR Coating

PART #	DESCRIPTION	USEFUL RANGE (nm)	CONTRAST RATIO	A/R	80/50
--------	-------------	-------------------	----------------	-----	-------

POLARIZING FILM

● PS007	High Contrast Linear Film .007" thk	400-700	Up to 3000:1		●
● PSA007	High Contrast Linear Film .007" thk (self adhesive)	400-700	Up to 3000:1		●
● PS010	High Contrast Linear Film .010" thk	400-700	Up to 3000:1		●
● PS030	Ultra High Contrast Linear Film .030" thk	400-700	Up to 7000:1		●
● HT025	High Temp. Linear Film .025" thk	400-700	Up to 5000:1		
● HT008	High Temp. Linear Film .008" thk	400-700	Up to 10,000:1		●
● HTA008	High Temp. Linear Film .008" thk (self adhesive)	400-700	Up to 10,000:1		●
● PG120	Ultra High Contrast Glass Linear Polarizer	400-700	Up to 10,000:1	†	●
● PS1000	VIS-NIR Wire Grid Linear Film Polarizer	400-2000	Up to 8000:1		●
● PSA1000	VIS-NIR Wire Grid Linear Film Polarizer (self adhesive)	400-2000	Up to 8000:1		●
● PG1000	Wire Grid Glass Linear Polarizer	400-2000	Up to 8000:1	†	●

† Oleophobic AR Coating

Batch-to-batch difference in the apparent color of the coatings or filter substrates can often be easily seen when looking at two examples of the same filter type. The color of the coating does not indicate a disparity in performance. Filters 62mm and greater have a surface quality tolerance of 60/40.

Due to continuous product improvement, specifications are subject to change without notice. For the most up-to-date information, [visit midopt.com](http://visitmidopt.com)

FILTERS: A NECESSITY, NOT AN ACCESSORY.



Midwest Optical Systems, Inc.

322 Woodwork Lane
Palatine, IL 60067 USA
info@midopt.com
+1 (847) 359-3550



F-014 Rev. 03/2019



MIDOPT.COM