



## Real-time Image Stabilisation for High-Zoom Surveillance Cameras

- Real-time image stabilisation of PAL or NTSC video images
- Improves the operational performance of high-zoom surveillance cameras
- Operates with live or recorded video
- Compact, simple to install hardware
- Can improve the performance of compressed video links
- Applications
  - Town centre CCTV
  - Cross-border monitoring
  - Long-range covert surveillance
  - Mobile recording
  - Video post-processing

StableEyes uses the very latest electronic image processing technology to reduce camera shake, leaving operators with clear and steady video. Installing StableEyes increases the effective operational range of high-zoom surveillance cameras where the slightest mechanical movement can introduce picture shake.

StableEyes is simply installed in-line with the viewing monitor and is compatible with either live or pre-recorded video. The system operates by employing ultra-fast video motion analysis techniques to remove the shake in real-time, resulting in stable video, which is far easier to view. StableEyes can also improve the performance of digital compression systems, such as Internet or ISDN video links, as stable images compress more efficiently.

StableEyes is the result of a technology partnership agreement between QinetiQ and Ovation Systems. StableEyes draws on QinetiQ's vast experience of video imaging for defence applications coupled with Ovation's production engineering capability. It is the culmination of over 10 man-years of hardware and software development.



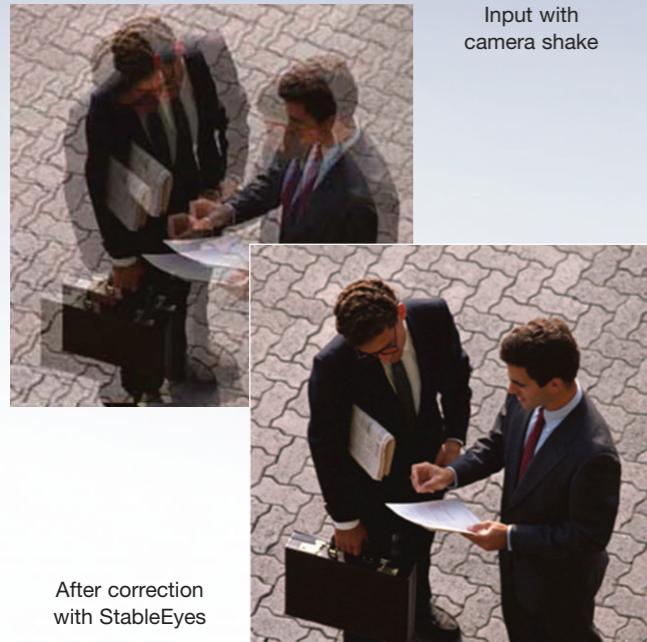

## typical StableEyes installation

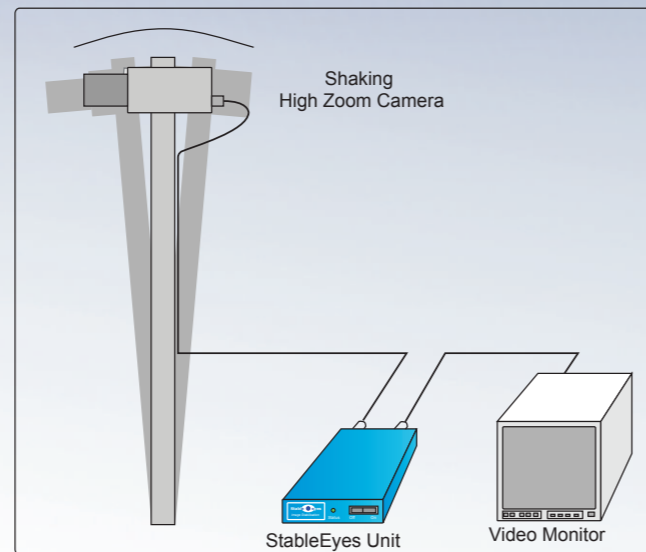

## installation

StableEyes is normally installed in-line with the viewing monitor with either a live camera feed or pre-recorded video. With CCTV systems, StableEyes is normally inserted in line with the operator's spot stabilisation, as only the viewed camera requires stabilisation. When not required, StableEyes may easily be bypassed by either switching off the unit, or via a remote switch / contact to ground.



## slow camera shutter speeds

In normal operation StableEyes performs best with camera shutter speeds of greater than 1/200 of a second. With slower shutter speeds, the image capture time can be long enough to introduce motion blur. Where slow shutter speeds are encountered (eg with low-light levels), StableEyes includes a sharpest frame mode, which automatically selects the best video frames that do not include blur.

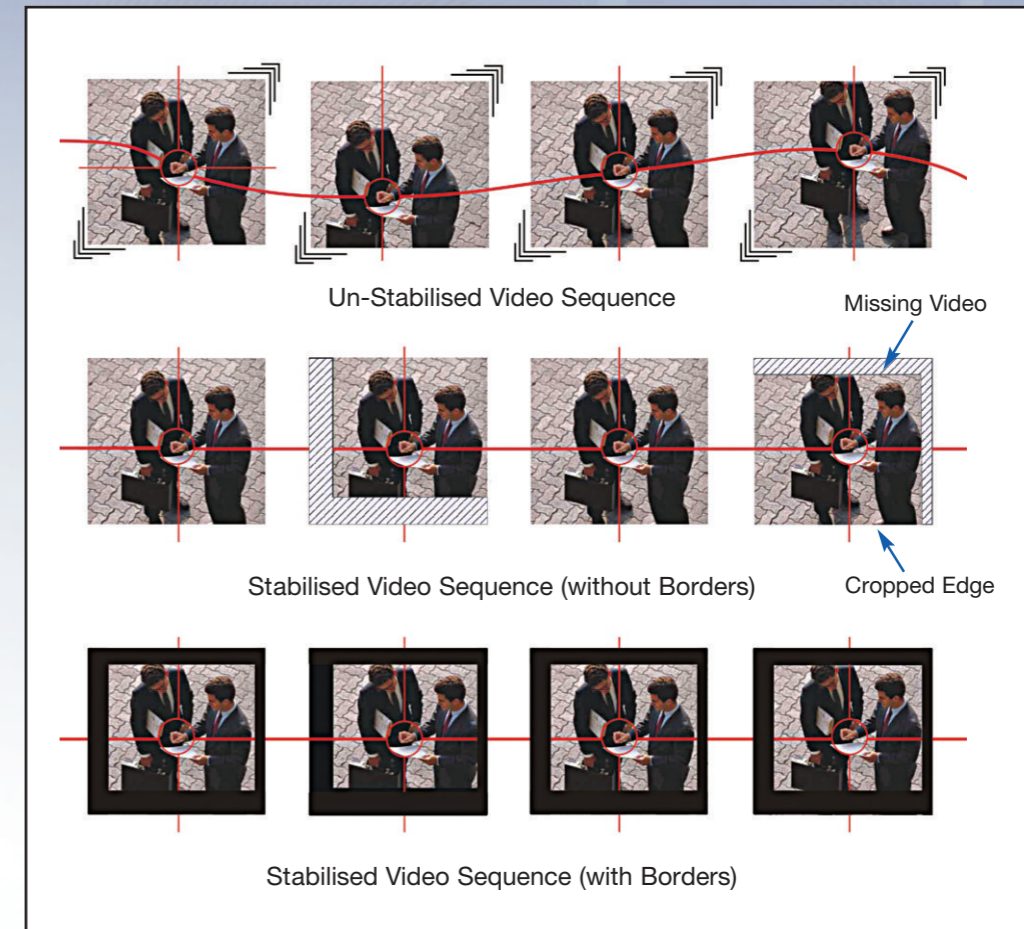

## overview of operation

StableEyes operates by locking onto detail within the incoming video to differentiate between shake and background. Once locked, StableEyes repositions each video frame to remove any shake resulting in clear and steady video. This is achieved by complex software algorithms running on the very latest multimedia hardware chip - the Philips Nexperia®. StableEyes has been specially developed to cope with demanding image stabilisation situations such as noisy video sources (eg low-light cameras), movement of large objects within the scene and operation with pan-tilt-zoom installations.

## operation with pan-tilt-zoom (ptz) installations

StableEyes automatically detects when a pan, tilt or zoom is taking place. When detected, the low frequency stabilisation capability of the system is reduced to keep the image centred for as long as possible. The high frequency stabilisation is maintained whilst a pan, tilt or zoom takes place.

## dynamic borders

StableEyes operates by moving each video field (picture) up, down, left or right in the opposite direction to the shake. This correction introduces cropping of the video at the picture edges, which can be very distracting with higher levels of shake. StableEyes solves this issue by introducing a black border to mask the cropped edges. The border slowly advances or retreats depending upon the level of shake, keeping the centre of the image, the area of interest, stable and free from distractions.

## award winning technology

StableEyes was selected from over 100 entries as the overall winner of the Security Industry Product Awards of 2004 at the International Fire & Security Exhibition and Conference (IFSEC), Europe's largest security trade fair.



## StableEyes dimensions and interfaces

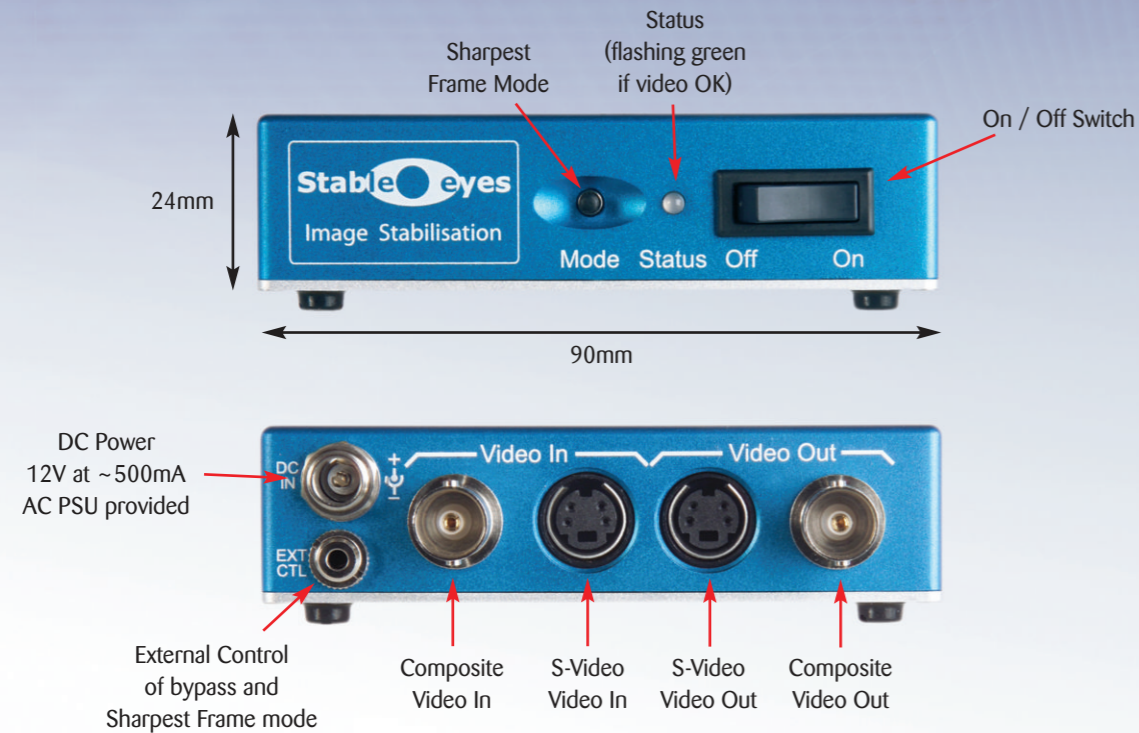

## outline specification

general		video	
Operating temperature range	0 to +40°C	Video input	Composite or S-Video
Mechanical size	160 x 90 x 24mm	Video input / output level	1 Vpp, 75 ohms
Finish	Hard blue anodised aluminium	Video Standards supported	PAL/NTSC (factory configured)
Weight	440g (approx)	Sampling resolution	PAL: 576 lines by 720 pixels NTSC: 488 lines by 720 pixels
DC power connector	Locking 2.1mm DC Jack	System delay	< 80mS
Operating voltage range	10 to 16 V DC	Video bypass	Active whilst un-powered
Power consumption	~ 6 Watts (~500 mA @ 12 V DC)	Stabilisation range	Up to 50% of screen
EMC compliance	EN5502 class A EN50082-1 FCC part 15B class A	Stabilisation frequency range	0.5Hz to 25 Hz (approx)
Standard Accessories	User guide, control cable AC mains PSU and Lead	external control	
		External control of bypass	Contact to earth / TTL level
		External control connector	4 Way 2.5mm Jack

Please note:  
Ovation Systems Ltd.  
reserves the right to  
change specifications  
without notice. E&OE

## Ovation Systems Ltd

Springfield Barn · London Road · Milton Common · Oxfordshire · OX9 2JY · UK

tel: +44 (0) 1844 279 638 fax: +44 (0) 1844 279 071 email: sales@ovation.co.uk

REF: SE/02/AUG06

www.ovation.co.uk