

PENSO®

The artificial intelligence-based vision unit

NEW



KEY ADVANTAGES

Works where all the others fail

PENSO® is designed to work on unpredictable variations and defects, as well as on objects difficult to model or without a golden reference.

Fast configuration, even faster prototyping

PENSO® full configuration requires hours, not weeks and produce feasibility studies in minutes, not days, without any programming required.

Adapts easily to the real working conditions

PENSO® helps the consistency of the inspection process by autoadjusting to changes on working conditions, self-learning from the ongoing process.

PENSO® is an artificial intelligence computational unit for imaging applications.

PENSO® self-learns the expected features of an object by simply looking at a small series of samples, regardless of the possible presence of defective product in the midst. Once trained, PENSO® will start operating autonomously and warning you if something unwanted happens.

Object modeling, often very difficult or even impossible is therefore no longer needed; moreover, you are not asked to define possible object variations or defects from the beginning, usually impossible.

Instead, as a human operator would do after observing some samples, PENSO® understands what will be considered normal and acceptable from now on. Since neither modeling or programming is needed, with just some elementary configuration tools you can immediately understand if an application is feasible or not and really save a lot of time. Then, with minimum additional effort, you can fine tune the application and make it fully working.

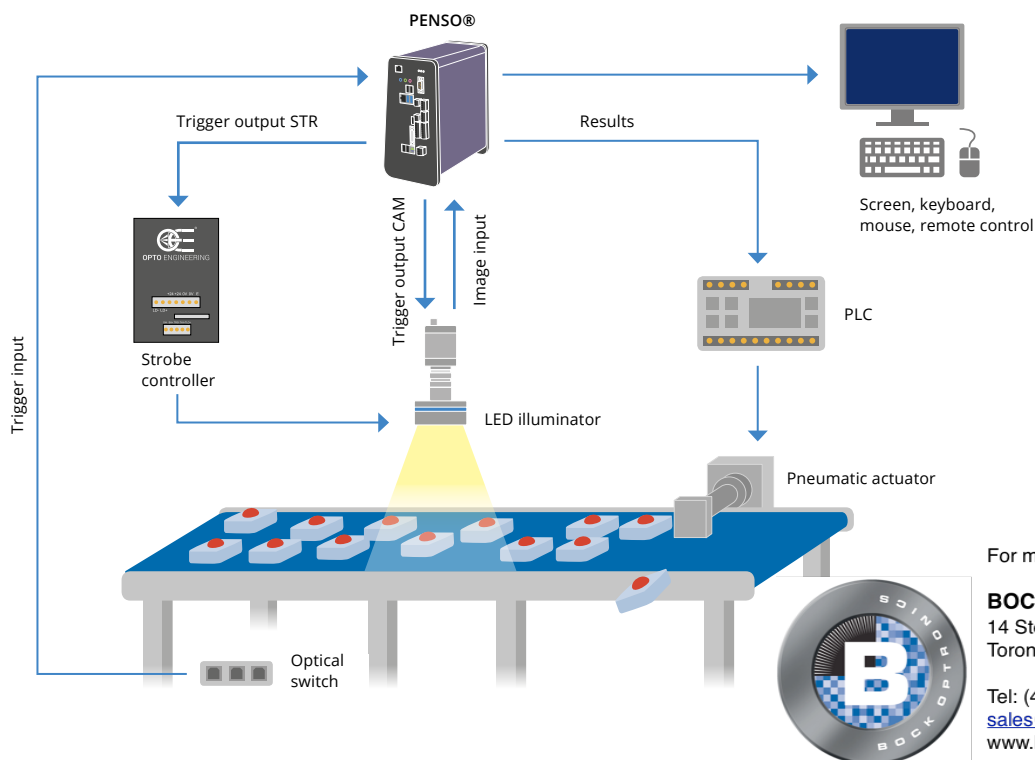

For more information please contact:

BOCK OPTONICS INC.
14 Steinway Blvd., Unit 7
Toronto, Ontario M9W 6M6

Tel: (416) 674-2804
sales@bockoptronics.ca
www.bockoptronics.ca



Installation

PENSO® is extremely easy to install: you simply need to connect inputs (camera, keyboard/mouse etc.) and outputs (synchronization signal, OK/NOK signal, etc.) and provide 24V DC. The basic settings are extremely simple and fast: image brightness, color correction, focusing and segmentation (i.e. is the process

of separating the product to be inspected from the background) are assisted by convenient software tools. The interaction with PENSO® is possible at all time through standard physical interfaces (keyboard, mouse and screen) or remotely, integrating PENSO® within the local network.

Learning

The **learning** process is easily performed by presenting some products on the production line and activating PENSO® in "LEARN" mode during normal operation.

Unlike traditional vision units, PENSO® autonomously learns the characteristics of your production in a few minutes: it is normally sufficient to present a few tens or a few hundreds of products during production to allow PENSO® to learn their characteristics without complicated settings.

PENSO® can tolerate up to 20% defective products during the learning phase, without affecting its ability to sort products correctly. PENSO® will be ready to check your production once the status bar is full.

Moreover, whenever the goods on your production line change or anytime you want to adjust your quality control process to new production parameters, you can just press the "LEARN" button and PENSO® will adjust itself accordingly.

Even during the learning phase, PENSO® continues to monitor production, quickly adapting to the new inspection criteria without having to stop the line: no other vision system is so flexible and easy to configure.

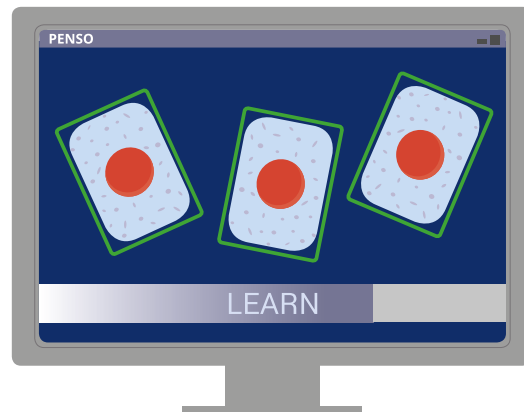

PENSO® in "LEARN" mode.

Sorting

Once the learning process is complete, PENSO® is ready for the sorting phase or "CHECK" phase: the products deemed inconsistent with the desired level of quality are reported and can be rejected from the line by interfacing PENSO® with most common ejection systems thanks to the preinstalled opto-isolated outputs.

PENSO® can store images of defective products, also keeping track of the reasons for rejection: this data can then be analyzed to improve the production process.

You can also adjust the "severity" level of the control parameters without having to stop the line. A dedicated slider bar allows the user to loosen or tighten the sorting criteria, quickly and easily adjusting PENSO® to new quality parameters.

PENSO® also allows a higher level of control: we can decide which features describing the object color and shape are taken into consideration by PENSO®, and how much PENSO® will consider them critical for the final decision (weight), all done in real time.

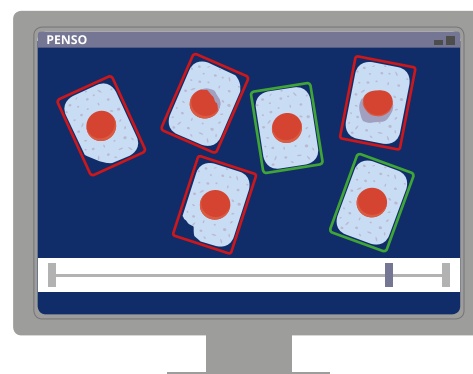
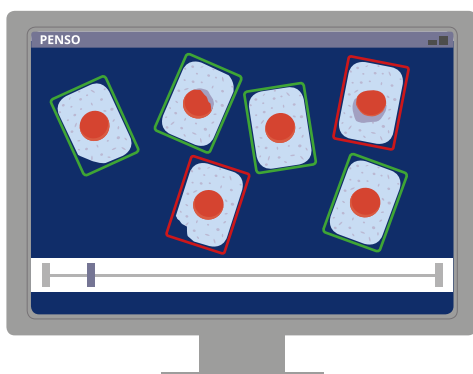

PENSO® set to low (left) or high (right) severity level.

PENSO® is successfully applied in many imaging applications. Here are some of the many cases where AI-driven imaging is the key to success.

Color/Mono imaging: Dishwasher tablets

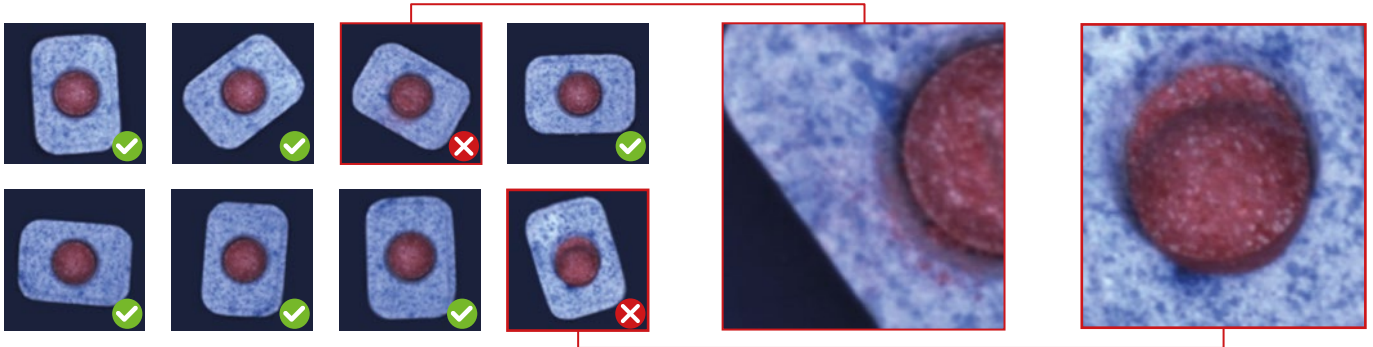

Dishwasher tablets come with natural variations: the density of blue over white soap, the roundness of the red core, etc. Nevertheless, PENSO® sees the defects as deviation from the average product shape or color distribution, exactly the way a human operator would.

Color/Mono imaging: Tealight candles



Inspecting candles is not an easy task: surface features and texture are always slightly different, making it hard to work within the usual deterministic imaging approach. An AI-driven inspection, on the other hand, skips the unimportant details and shows us only what matters!

3D imaging

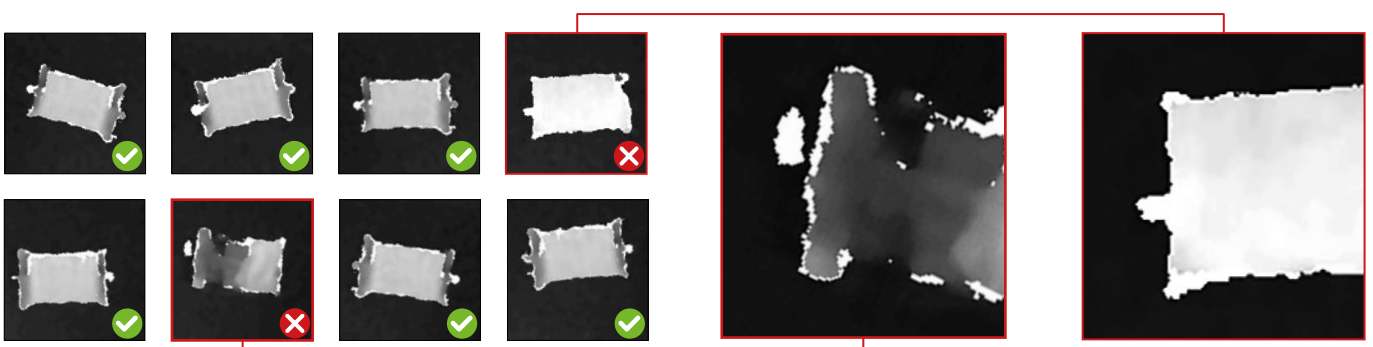

The typical output of a 3D camera is a monochrome picture of the object, where dark regions are lower and bright regions are higher (height map). In this example, a package with broken or irregular crackers is first detected by PENSO® because of its unusual dark spots, corresponding to the missing chunks. Too many crackers in the package, instead, appear as a uniform brighter-than-average tint, corresponding to the increased height.

Thermal imaging / IR / X-Ray*

PENSO® works with array images, looking at change of shape and color. For this reason, the source of the image does not matter

- from IR application to X-ray vision, if the camera output is a 2D image, PENSO® can process it!

*might require hardware/software customization



SOFTWARE FEATURES

System calibration

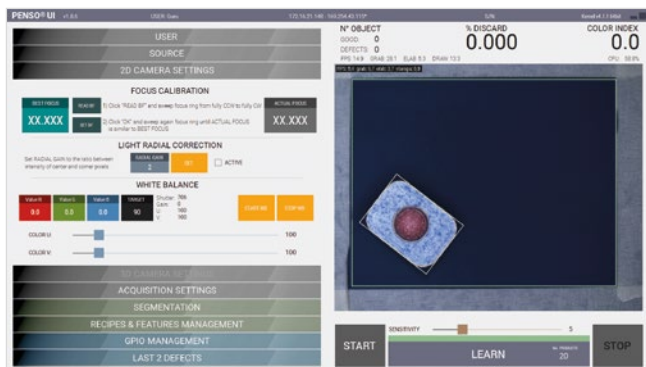

When setting up the image for PENSO®, we want to make sure it represents the product as accurately as possible. Therefore, our first step is system calibration: an intuitive tool guides the user through the optimization of focusing, color calibration and light intensity.

Image segmentation

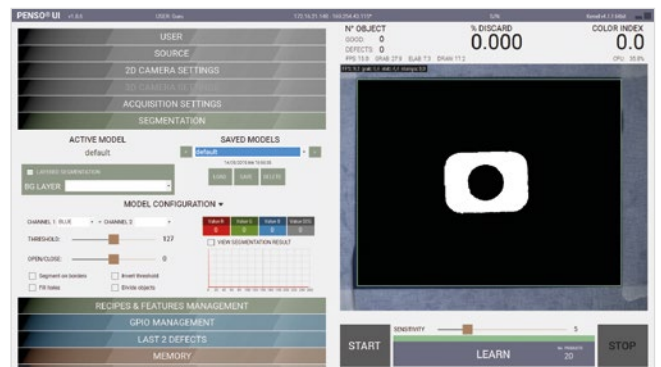

In our second step, we need to tell PENSO® how to separate the object from the surface underneath (segmentation). This goal is also achieved using a simple software tool, which lets us play with intensity thresholding and color differences to quickly and easily get the best result.

Feature extraction management

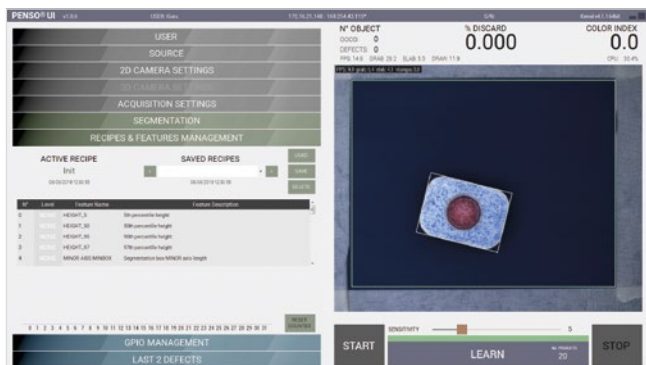

Once we set our best image and the LEARN process is completed, we can start fine-tuning the sorting process, selecting from a growing number of features the ones that best relate to our specific sorting process. PENSO® will show us in real time how a single feature and its relative importance (weight) contributes to the overall choice between OK and NOK sample.

*Do you need a non-standard feature? We'll create it for you!
Contact us to know about customized filters in PENSO®.*

Model		PENSO-01
Description	Artificial Intelligence-based Vision Unit	
Application	In-line inspection	
Camera ¹	Matrix Vision up to 5 MPx , 3D cameras (see Accessories)	
Number of parts per second ²	20	
LED indicators	Power, Status and Error	
N° of storable images ³	≈ 800K	
Ports		
Input		
Synchronization input	2, opto isolated, common reference	
Commands	6, opto isolated, common reference	
Output		
Status	4, opto isolated, common reference	
Synchronization output	2 strobe trigger, opto isolated, common reference, 1 camera trigger, opto isolated	
Results	6, opto isolated, common reference	
Elaborated	1, opto isolated	
Communication		
USB 3.0	2 (camera dedicated)	
Ethernet	1 (camera dedicated) + 1	
RS232	1	
RS485	1	
USB 2.0	4	
1 PS/2	1 (keyboard and mouse)	
HDMI	1	
DVI	1	
Power Requirements		
Voltage	V, DC	24 ± 5%
Maximum power consumption	W	100
Mechanical specifications		
Width W	mm	128
Length L	mm	230
Height H	mm	226
Weight	Kg	2.5
Material	Aluminium	
Mounting	DIN mount	
Environment		
Operating temperature	°C	10-40
Storage temperature	°C	0-50
Humidity	20-85% (with no condensation)	
IP class	no IP class	
Installation	indoor use only	

- 1 Non-standard cameras available upon request (customization).
- 2 Estimated value. The number of inspected parts per second may vary depending on image resolution, line speed and number of activated features.

- 3 Estimated value based on 250 Kbytes images stored in 200 GB SSD memory.

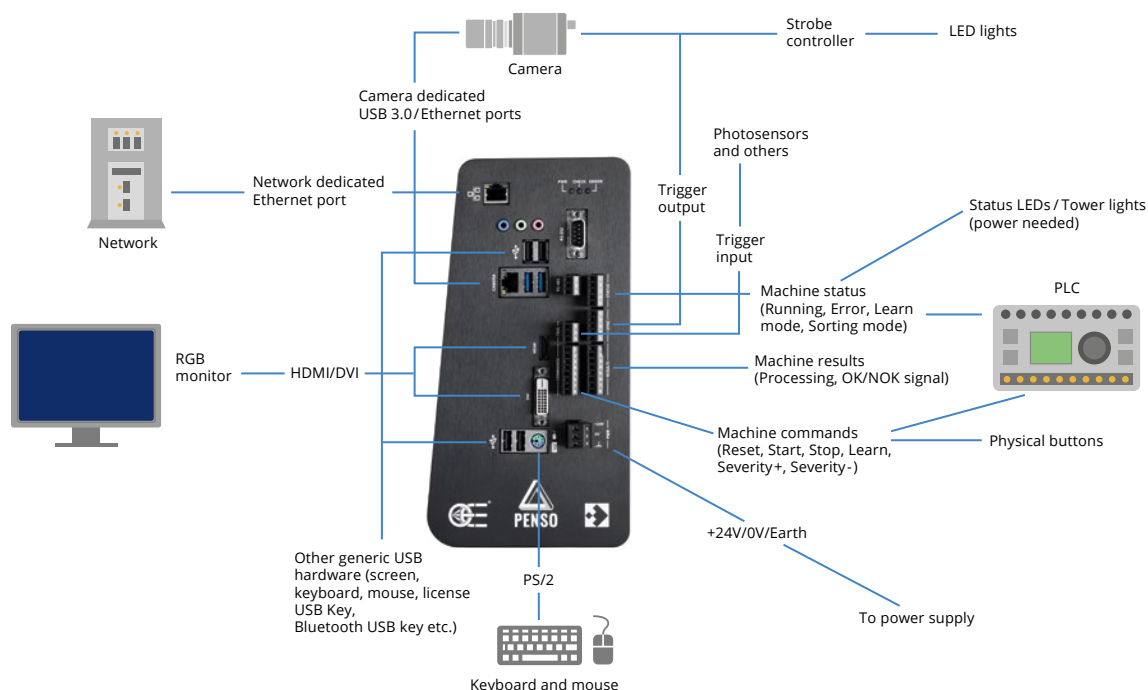

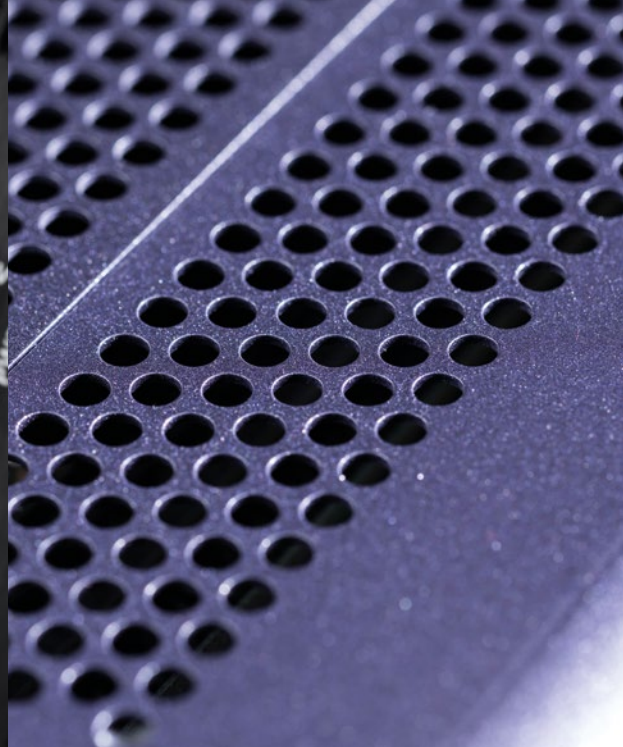
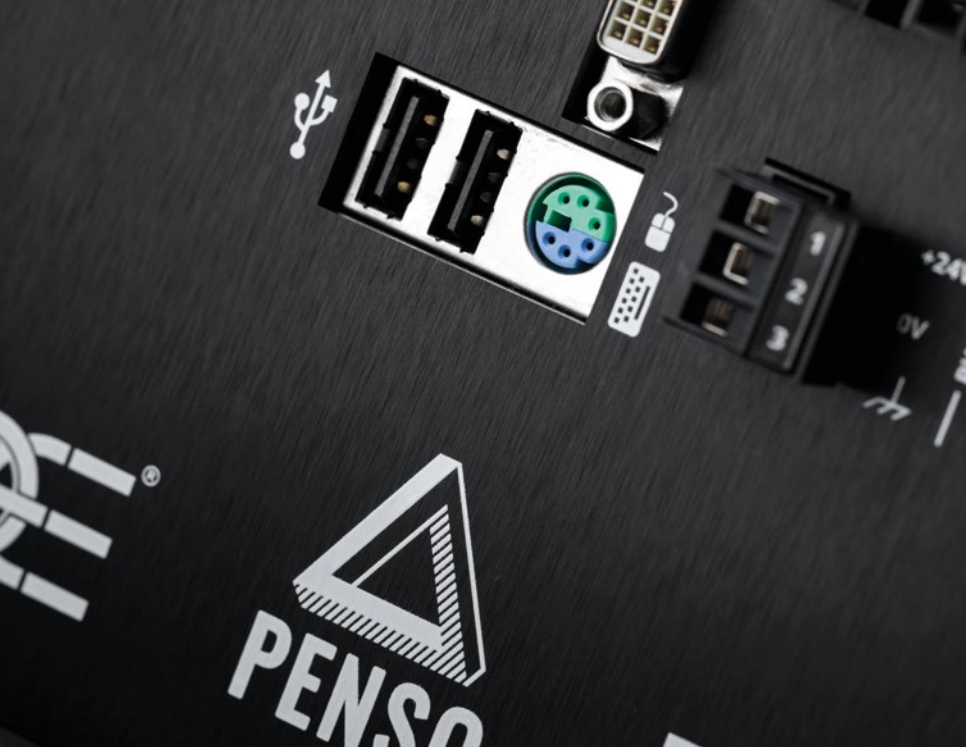

ACCESSORIES AND COMPATIBLE PRODUCTS

Power supply

RT-DRT-240-24	DIN rail power supply 400V ac three-phase - 24V dc 240 W
RT-DRP-240-24	DIN rail power supply 240V ac - 24V dc 240 W
RT-70261132	Power cord with schuko plug - open end cable, 3m 10A 250V, single-phase

Cameras

RT-mvBC-X102eC	CMOS camera GIGE, 1280 x 1024 color, 1/1.8", 60 Hz, IR cut, C-mount, I/O
RT-mvBF3-2032aC-1112	CMOS camera USB3, 2064 x 1544 colour, 1/1.8", 55 Hz, IR cut, C-mount, with I/O
RT-mvBC-X104iC	CMOS camera GIGE, 2064 x 1544 color, 1/1.8", 37 Hz, IR cut, C-mount, I/O
RT-mvBF3-2051aC-1112	CMOS camera USB3, 2464 x 2056 color 2/3", 35.6 Hz, IR cut, C-mount, with I/O
RT-mvBC-X105bC	CMOS camera GIGE, 2464 x 2056 Colour sensor, 2/3", 23.5 Hz, IR cut, C-mount, I/O
STLTCM01	3D Structured-light Camera, 0.6-8.0 m range, USB 2.0

Optics

EN2MP0814	Megapixel lens, focal length 8 mm, f# 1.4-C, C-mount
EN2MP1214	Megapixel lens, focal length 12 mm, f# 1.4-C, C-mount
EN2MP1614	Megapixel lens, focal length 16 mm, f# 1.4-C, C-mount
EN2MP2514	Megapixel lens, focal length 25 mm, f# 1.4-C, C-mount
EN2MP3514	Megapixel lens, focal length 35 mm, f# 1.4-C, C-mount
EN2MP5018	Megapixel lens, focal length 50 mm, f# 1.8-C, C-mount

Lighting components - Strobe

LTLAB2-W	Diffusive strobed low angle ring light illuminator - medium size high power white
LTBP048216-W	High power strobed LED backlight, 48 x 216 mm lighting area, white
LTDMB2-W	Diffusive strobed dome illuminator - medium size high power white
LTDV1CH-17V	Strobe controller 1 channel variable current 5 mA - 17A
LTDV6CH	Strobe controller 6 channels

Lighting components - Continuous

LTZGK090-00-4-W-24V	LED ringlight, 4 LED rows, outer diameter 92 mm, 0°, white, 24V
LTZPFL200-00-6-W-24V	LED bar light, 6 LED rows, 200X26.3 illumination area, white, 24V
LT4WRG150-00-1-W-24V	LED dome light, 185 mm outer diameter, white, 24V
LTCGR1000-D1	Analogue lighting controller unit, 1 channel, 24V, 2A, constant mode, power adaptor 24V plug
DFLTZGK090-00-4	Diffuser for LED ringlight, 4 LED rows, outer diameter 92 mm, 0°
DFLTZPFL200-00-6	Diffuser for LED bar light, 6 LED rows, 200X26.3 illumination area
CBSLH-24V-F-3M	Illumination cable, side A flying leads, side B SM 3 way female connector, 24V - 3m

Cables

CBUSB3001	Passive USB 3.0 cable, industrial level, horizontal screw locking, 3 m
CBGPI001	I/O cable, side 1 HIROSE 12 pin, side 2 cable end, 3 m
CBETH003	Ethernet cable, CAT6, industrial level, high flexible cable with screw, 5 m
CBUSB20ACT01	Active USB 2.0 cable, industrial level, screw locking, 10 m

Other

RT-WTB9-3P246	Background suppression sick photoelectric sensor 20 - 350 mm detection range, PNP output, block style
RT-10060911	Set of 2 8" x 10" white balance/exposure cards - 18% grey and 90% white for color calibration

PENSO-KIT case

Artificial Intelligence for machine vision - starter kit

NEW



The **PENSO-KIT case** includes a selection of Opto Engineering® components that will easily allow you to bring Artificial Intelligence into your applications.

This versatile kit is ideal for system integrators that are frequently dealing with new, challenging inspection processes. Artificial Intelligence can be an extremely powerful resource; therefore, it is extremely important to have quick access to it for testing, feasibility studies and demonstrations.

The kit contains PENSO®, our innovative artificial intelligence-based vision unit, together with all necessary hardware to set it up: power supply, proximity sensor, color camera, 3D camera, lens, illuminator, strobe controller, cables and mounting mechanics. Saving time from choosing all the necessary individual components, a kit offers an ideal development tool at a bundle pricing.

Get the PENSO-KIT now, and start discovering the advantages of Artificial Intelligence!

Part number	Products included	Description
PENSO-KIT	PENSO-01	Artificial Intelligence-based Vision Unit
	RT-DRP-240-24	DIN rail power supply 240V ac - 24V dc 240 W
	RT-70261132	Power cord with schuko plug - open end cable, 3m 10A 250V, single-phase
	RT-mvBF3-1013C-1112	CMOS camera USB3, 1280 x 1024 gray, 1/1.8", 60 Hz, IR cut, C-mount, with I/O
	CBUSB3001	Passive USB 3.0 cable, industrial level, horizontal screw locking, 3 m
	CBGPI0001	I/O cable, side 1 HIROSE 12 pin, side 2 cable end, 3 m
	STLTCM01	3D Structured-light Camera, 0.6-8.0 m range, USB 2.0
	CBUSB20ACT01	Active USB 2.0 cable, industrial level, screw locking, 10 m
	EN2MP1214	Megapixel lens, focal length 12 mm, f# 1.4-C, C-mount
	LTZGK090-00-4-W-24V	LED ringlight, 4 LED rows, outer diameter 92 mm, 0°, white, 24V
	DFLTZGK090-00-4	Diffuser for LED ringlight, 4 LED rows, outer diameter 92 mm, 0°
	LTDV1CH-17V	Strobe controller 1 channel variable current 5 mA - 17A
	LTICGR1000-D1	Analogue lighting controller unit, 1 channel, 24V, 2A, constant mode, power adaptor 24V plug
	CBSLH-24V-F-3M	Illumination cable, side A flying leads, side B SM 3 way female connector, 24V - 3m
	CBPH003	Photoelectric sensor cable, M12 connector to flying leads, length 5m
	RT-WTB9-3P246	Background suppression sick photoelectric sensor 20 - 350 mm detection range,PNP output, block style
	RT-10060911	Set of 2 8" x 10 " white balance/exposure cards - 18% grey and 90% white for color calibration