

LVZ3X5016N

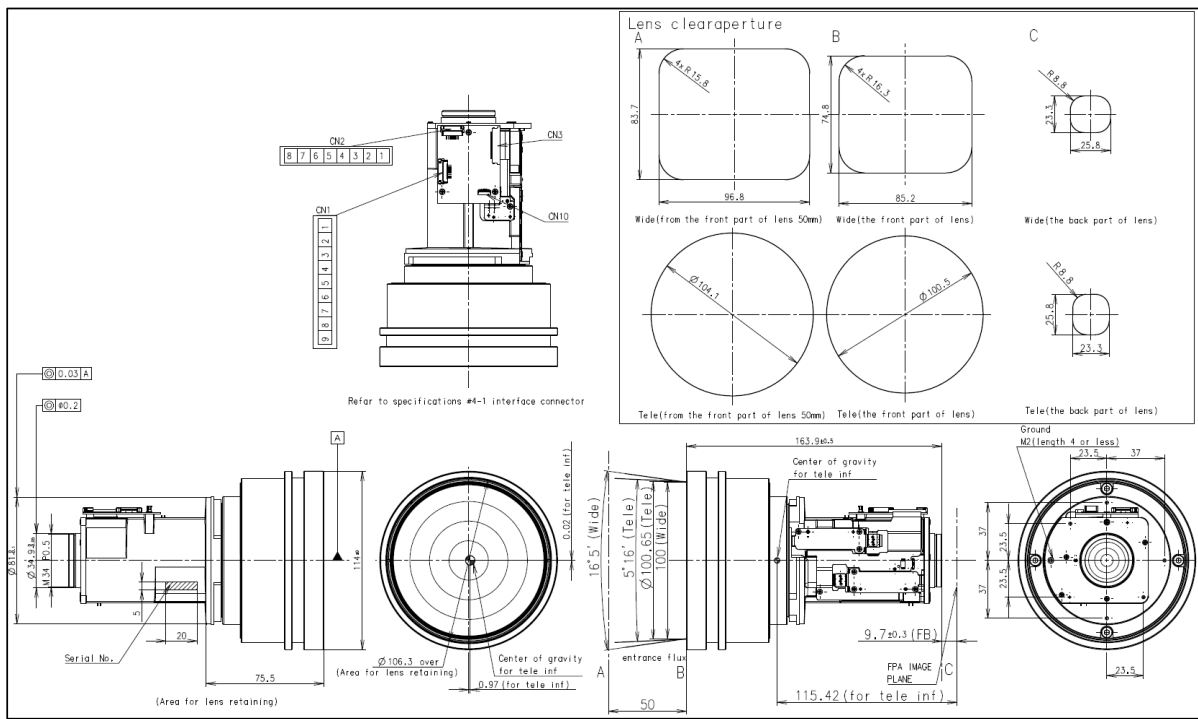

Spectral wave length		8-14 μ m
Focal length		50-150mm
F Number		F/1.6
Zoom ratio		3X
Flange back focal distance		9.7mm \pm 0.3mm (in Si)(Barrel rear edge to image plane)
Detector package window		(Si) t=0.66mm
Back focal distance		WIDE: 28.21mm TELE: 28.02mm
Effective image circle dia.		\geq ϕ 14.5mm
FOV (Note *1)	H	WIDE : 12.5 / TELE : 4.1° (Note *1)
	V	WIDE : 10.0° / TELE : 3.3° (Note *1)
	D	WIDE : 16.1° / TELE : 5.3° (Note *1)
Focusing system		Internal focusing system
MOD (Minimum object distance)		WIDE : 7.0m / TELE : 7.0m
Max. object distance (detection)		WIDE : 1,459m / TELE : 4,408m (Note *2)
Mechanical	Max. barrel dia. X length	ϕ 114mm x 164mm
	Weight	1,170g
	Optical image stabilization	N/A
	Optical zoom	Motorized
	Focus control	Motorized
	Active Athermalization	YES
	Mount	threaded, M34xP0.5
Electronic /Electric	Power supply	9 V DC
	Power consumption	\leq 0.7A
	Communication	Full duplex asynchronous serial communication
Reliability	Operating temp. (Performance)	-10°C~70°C
	Operating temp. (Function)	-20°C~80°C
	Water & dust proof	IP67 (front lens only)
	Front element coating	DLC coating

(Note 1) The field of view have been calculated based on a sensor size of 10.88mm(V) x 8.7mm(H) (13.9mm diagonal). (VGA 17.0 μ m pixel pitch)

(Note 2) The max. object distance (detection) is a theoretical value calculated for seeing human sized objects based on Johnson's criteria under the assumption that VGA-17 μ m pixel pitch sensor is used. It is not an actual measured value.

* Product specification are subject to change without notice.

* Custom-made lenses are available according to customers' requested design/manufacturing specifications. Please feel free to inquire.

TAMRON[®]

SC002B0000-02

LVZ3X3516N/A

For more information please contact:



BOCK OPTRONICS INC.
 14 Steinway Blvd., Unit 7
 Toronto, Ontario M9W 6M6
 Tel: (416) 674-2804
sales@bockoptronics.ca
www.bockoptronics.ca

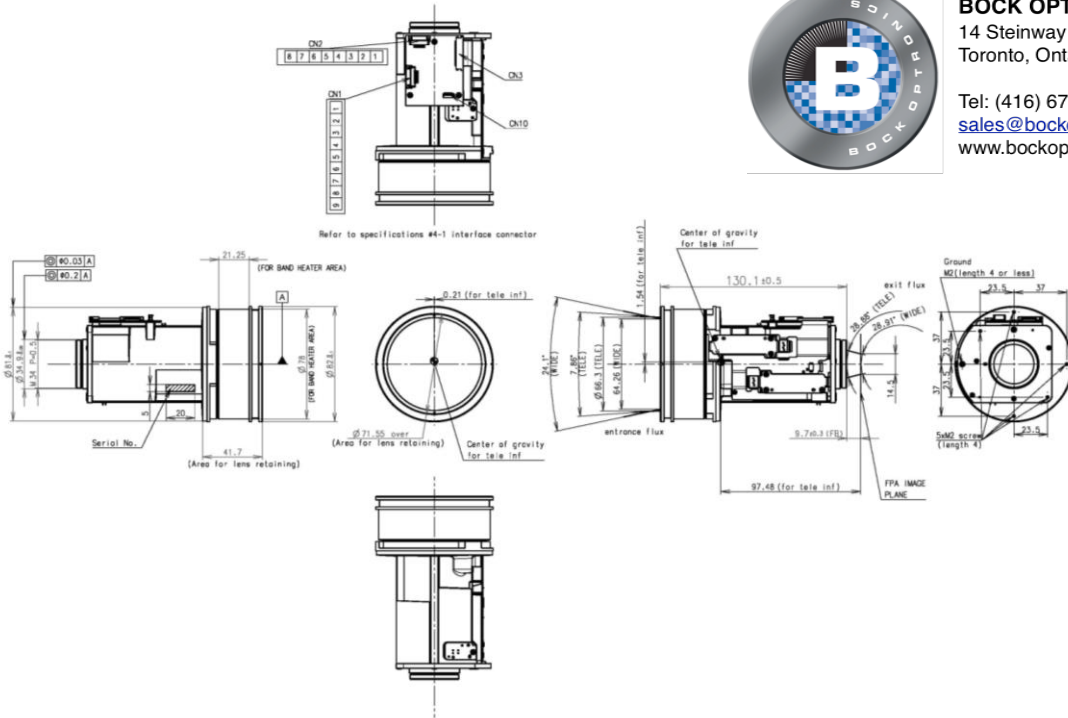

Spectral wave length		8~14μm
Focal length		35-105mm
F Number		F/1.6
Zoom ratio		3X
Flange back focal distance		9.7mm±0.3mm (in Si)(Barrel rear edge to image plane)
Detector package window		(Si) t=0.66mm
Back focal distance		WIDE: 28.21mm TELE: 28.10mm
Effective image circle dia.		≥φ 14.5mm
FOV (Note *1)	H	WIDE: 18.0° / TELE: 5.9° (Note *1)
	V	WIDE: 14.3° / TELE: 4.8° (Note *1)
	D	WIDE: 23.1° / TELE: 7.6° (Note *1)
Focusing system		Internal focusing system
MOD (Minimum object distance)		WIDE: 7.0m / TELE: 7.0m
Max. object distance (detection)		WIDE: 1013m / TELE: 3083m (Note *2)
Mechanical	Max. barrel dia. X length	φ 82mm x 130.1mm
	Weight	490g
	Optical image stabilization	N/A
	Optical zoom	Motorized
	Focus control	Motorized
	Active Athermalization	YES
	Mount	threaded, M34xP0.5
Electronic /Electric	Power supply	9 V DC
	Power consumption	≤0.7A
	Communication	Full duplex asynchronous serial communication
Reliability	Operating temp. (Performance)	-10°C~70°C
	Operating temp. (Function)	-20°C~80°C
	Water & dust proof	IP67 (front lens only)
	Front element coating	DLC or AR coating (Selectable)

(Note 1) The field of view have been calculated based on a sensor size of 10.88mm(V) x 8.7mm(H) (13.9mm diagonal). (VGA 17.0μm pixel pitch)
 (Note 2) The max. object distance (detection) is a theoretical value calculated for seeing human sized objects based on Johnson's criteria under the assumption that VGA-17μm pixel pitch sensor is used. It is not an actual measured value.

* Product specification are subject to change without notice.
 * Custom-made lenses are available according to customers' requested design/manufacturing specifications. Please feel free to inquire.

