

4

3

2

1

REVISIONS

ZONE	REV.	DESCRIPTION	DATE	APPROVED
	A		7/30/2019	

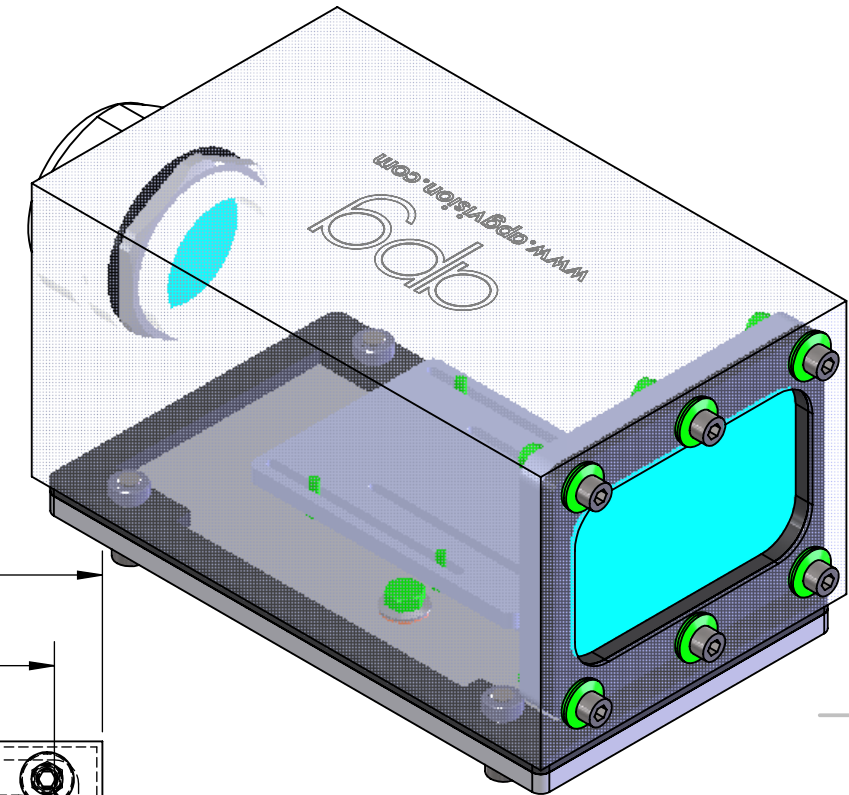
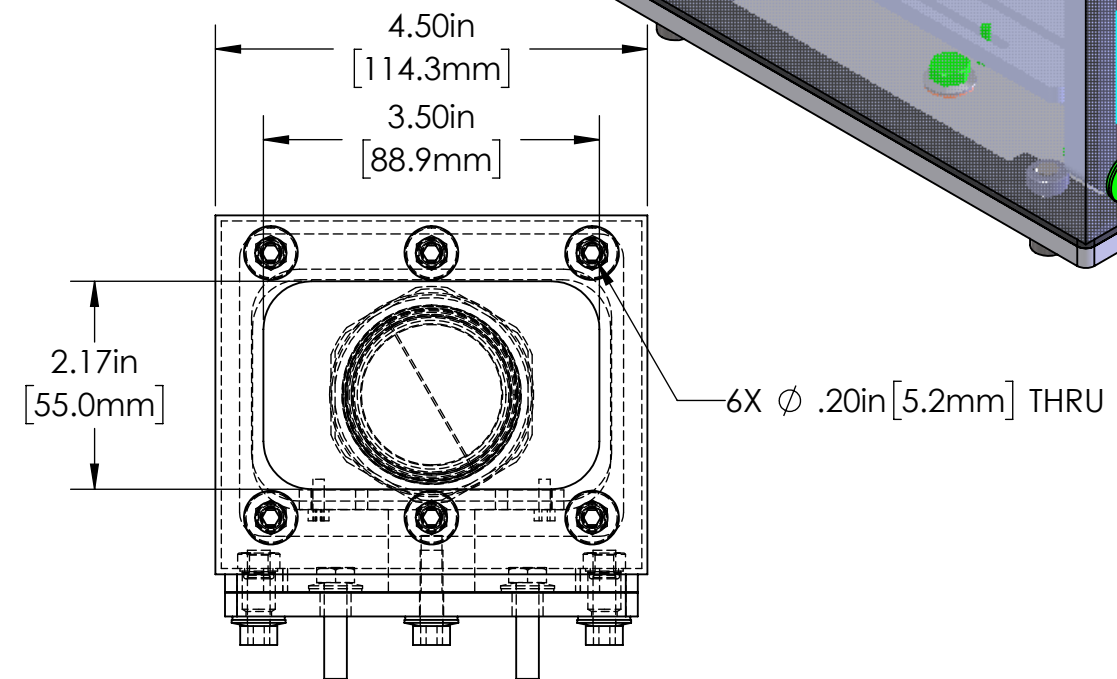
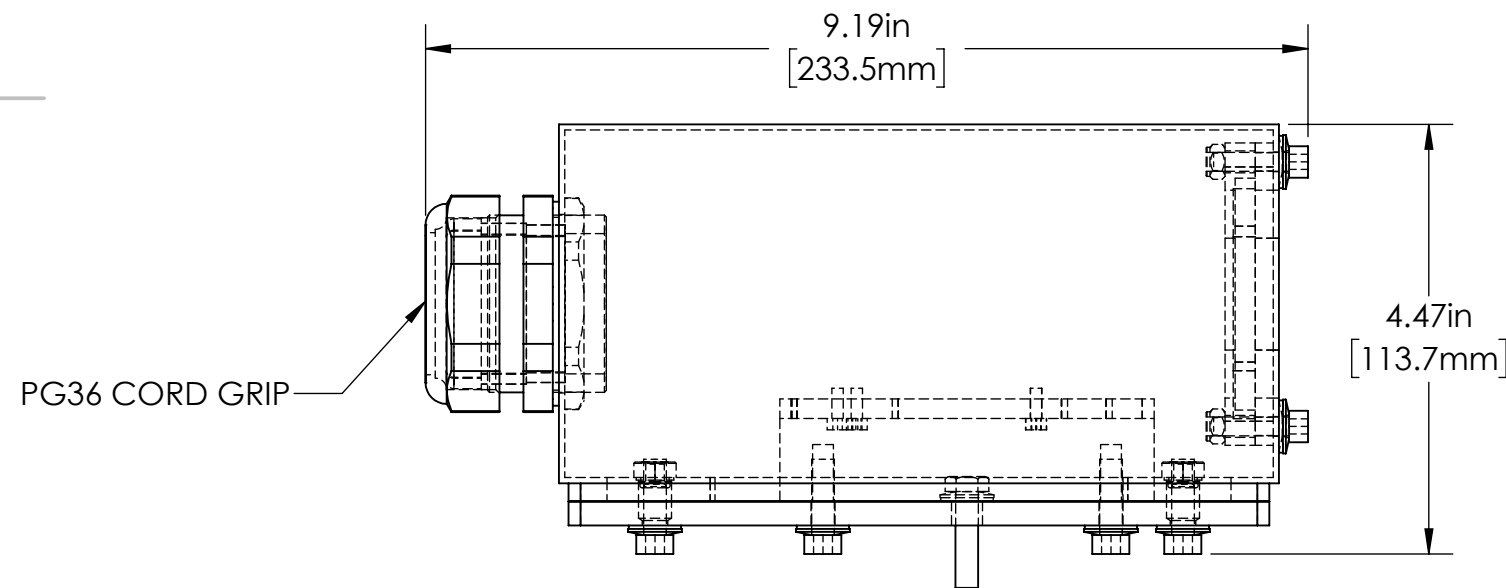
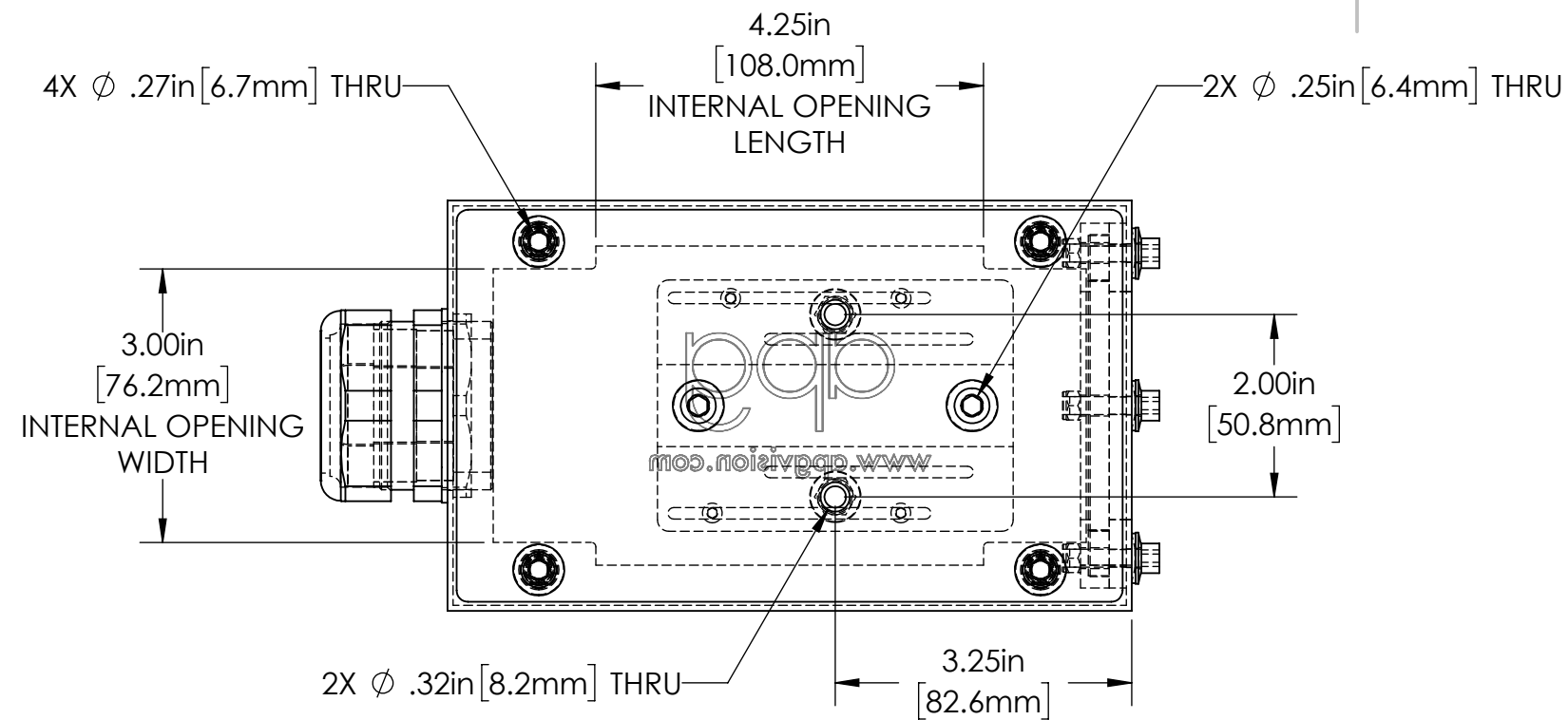

B

B

A

A

4

3

2

1

TOLERANCES UNLESS OTHERWISE SPECIFIED

MACHINING		SHEET METAL	
X.X	0.0250"	HOLE TO HOLE (SAME SURFACE)	X.X 0.030"
X.XX	0.0100"	X.XX	0.010"
X.XXX	0.0050"	X.XXX	0.005"
X.XXXX	0.0005"	X.XXX	0.015"
ANGULAR	0.5°	HOLE TO FOLDED EDGE	X.X 0.035"
DEBURR ALL		X.XX	0.025"
		X.XXX	0.015"
		FOLD TO FOLD	X.X 0.045"
		X.XX	0.035"
		X.XXX	0.020"
		ANGULAR	1.0°

ALL WEIGHTS ARE IN POUNDS

THIS PRINT IS THE PROPERTY OF ALLISON PARK GROUP. THE INFORMATION CONTAINED HEREIN IS CONFIDENTIAL. IT IS NOT TRANSFERABLE. IT IS FURNISHED WITH THE CLEAR UNDERSTANDING THAT IT IS NOT TO BE TRACED, REPRODUCED OR USED IN ANY PROCESS OF MANUFACTURING WITHOUT WRITTEN PERMISSION FROM THE OWNER AND IS RETURNABLE UPON DEMAND. ANY INFRINGEMENT UPON THE PATENT RIGHTS SHOWN HEREIN, WHETHER IN PART OR WHOLE, WILL BE PROSECUTED.

AS PART OF OUR POLICY OF CONTINUING DEVELOPMENT, ALLISON PARK GROUP RESERVES THE RIGHT TO ALTER SPECIFICATIONS WITHOUT PRIOR NOTICE.



Allison Park Group, Inc (APG)
 4055 Alpha Drive
 Allison Park, PA 15101 USA
 Phone +1 (412) 487-8211
 apgvision.com

DESCRIPTION: 42D-AJ ENCLOSURE				
MATERIAL: SEE BOM				
FINISH: SEE BOM				
DRAWN BY: TWD	DATE: 4/1/2020	SCALE: 1:2	SHT-SIZE: B	APPROX. WEIGHT: 1.3419
CHECKED BY:	DATE:	PART NUMBER: 42D-AJ		REVISION: A

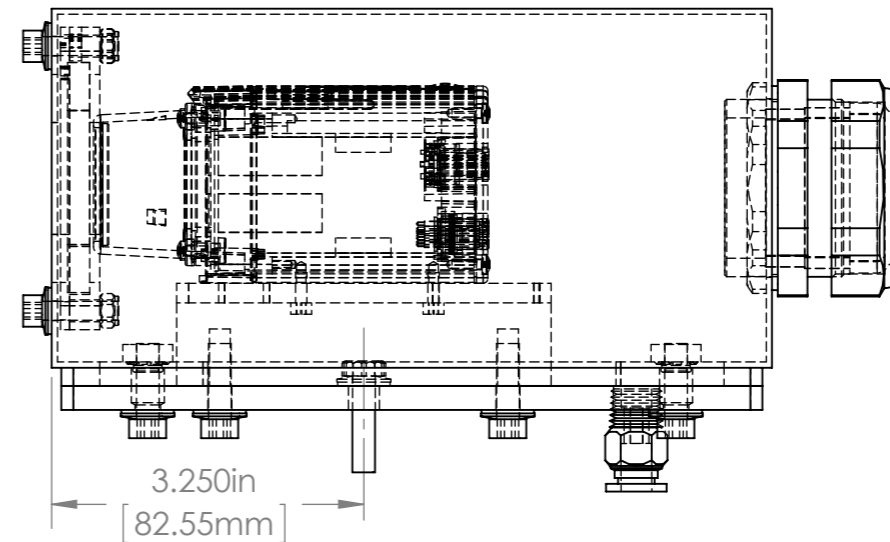
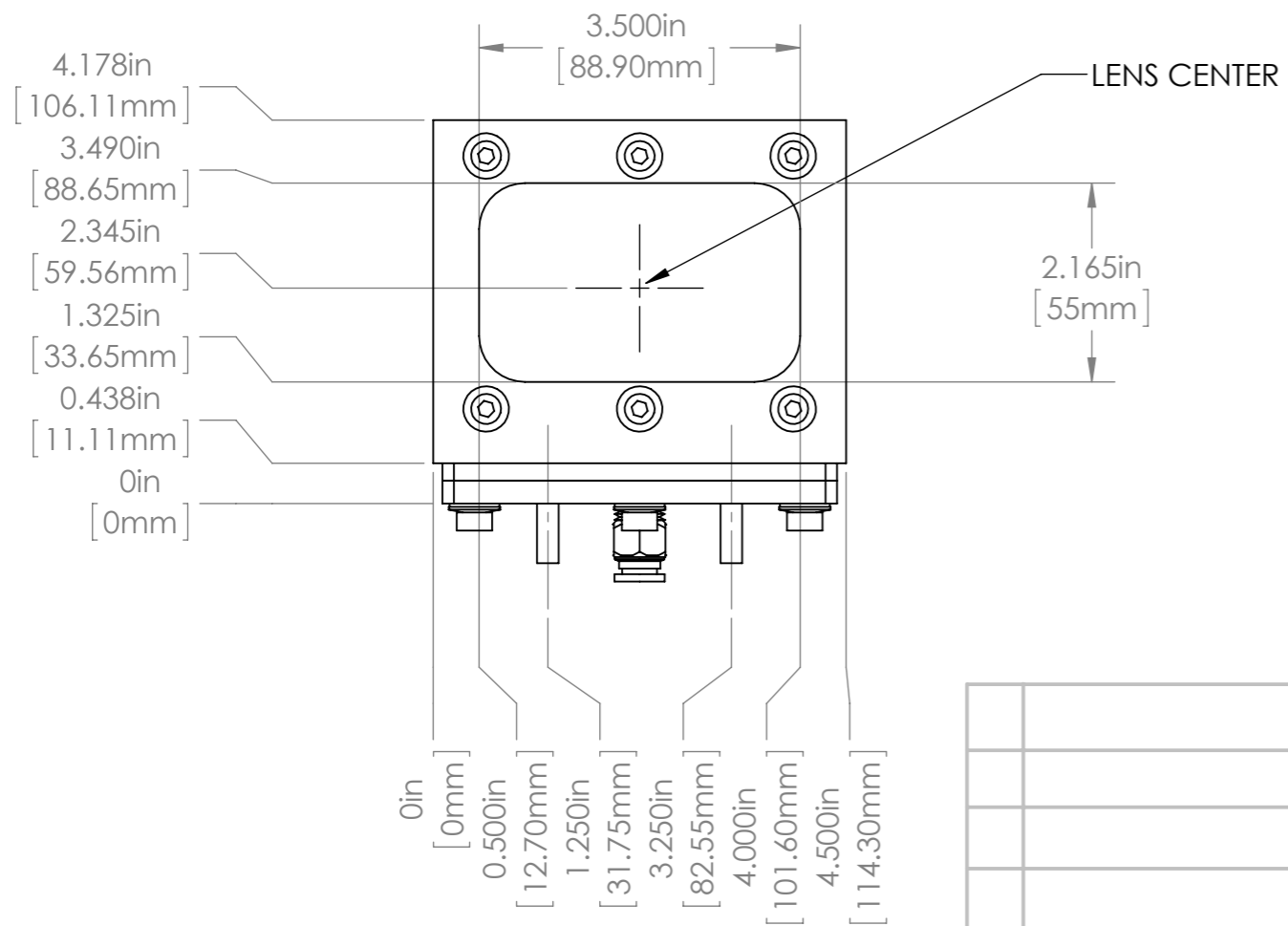
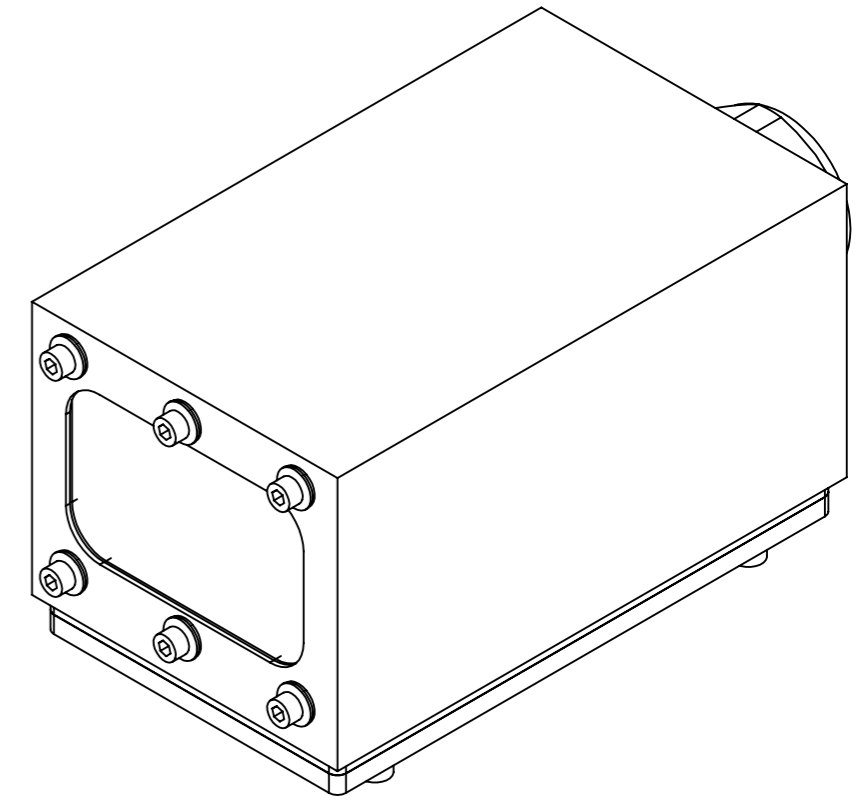
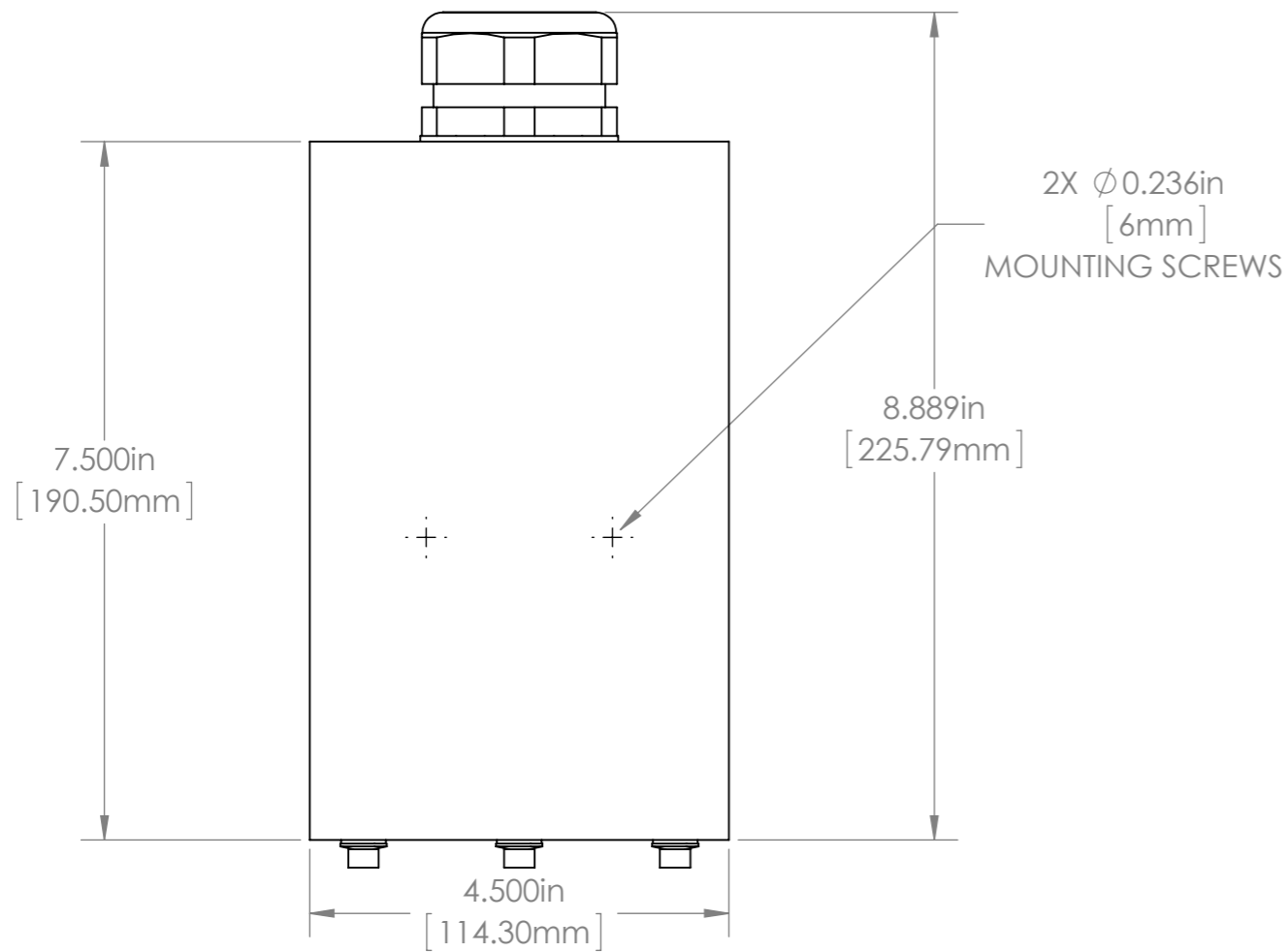

				UNLESS OTHERWISE SPECIFIED: DIMENSIONS ARE IN INCHES SURFACE FINISH: TOLERANCES: .000= +/- 0.005" .00= +/- 0.010"		FINISH: BURNISHED		DO NOT SCALE DRAWING		REVISION	
				LINEAR:		DEBUR AND BREAK SHARP EDGES		Allison Park Group, Inc. (APG) 4055 Alpha Drive Allison Park, PA 15101 USA			
				DRAWN SCHUBERT		SIGNATURE		DATE 1/22/2014		This document is the property of APG and is considered company confidential. The information in this document is the property of APG and may not be used, reproduced, or distributed in whole or in part without the prior written permission of APG	
				CHK'D				Phone +1 (412) 487-8211		TITLE: 42D-AE (DM500 GIs ACFP) ASSY	
				APPV'D				Fax +1 (412) 486-3157			
				MFG				www.apgvision.com			
				Q.A				MATERIAL: 304 STAINLESS STEEL BODY 6061 T6 ALUMINUM BASE		DWG NO. 42D-AE ASSY DIMS	
				NOTES:				WEIGHT:		SCALE: 1:5	
				NO. CHANGE		DATE INIT.				SHEET 1 OF 1	
										A3	

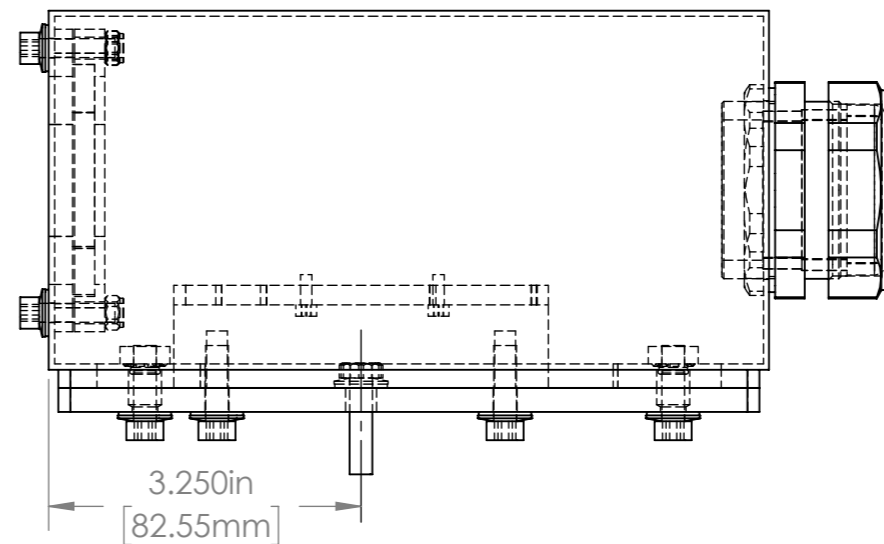
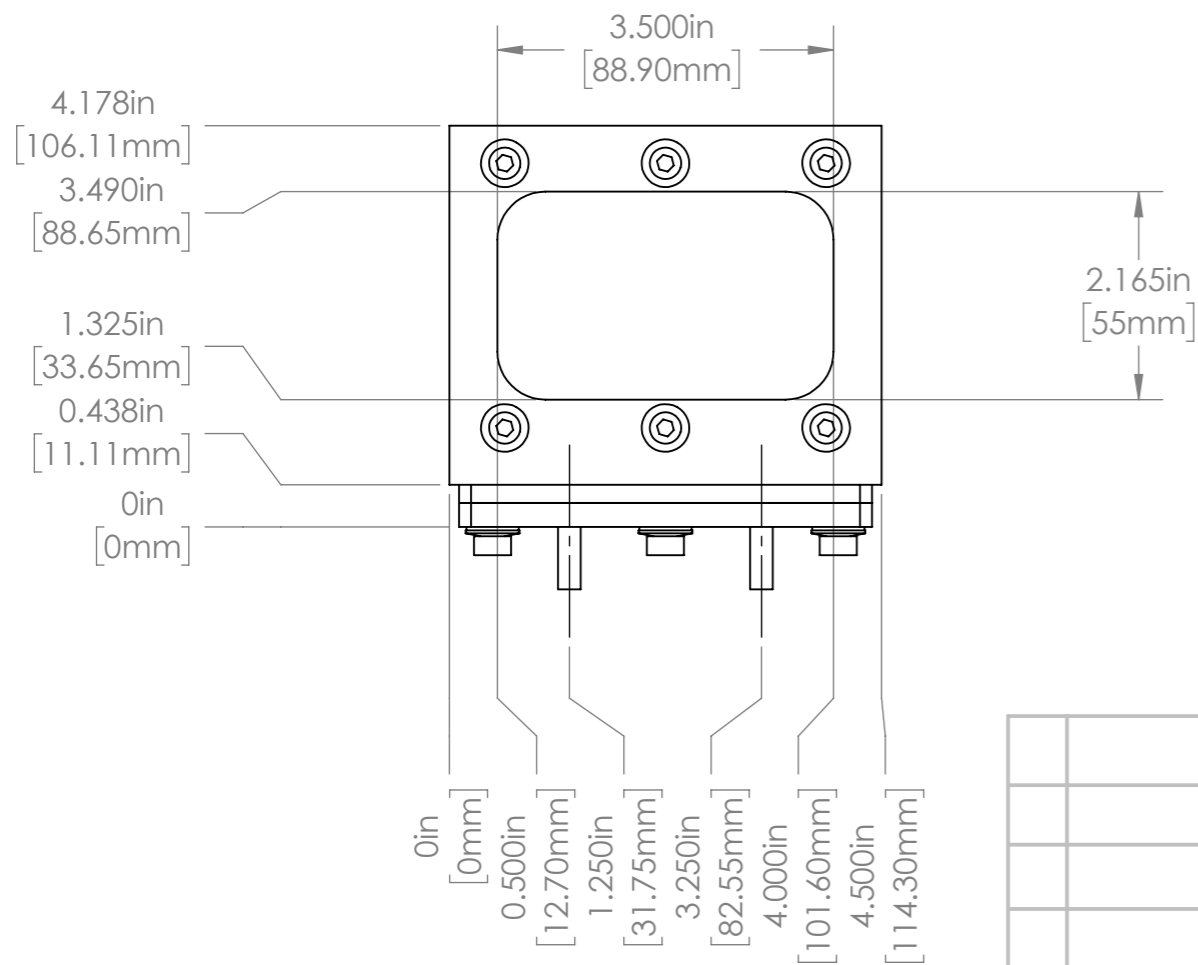
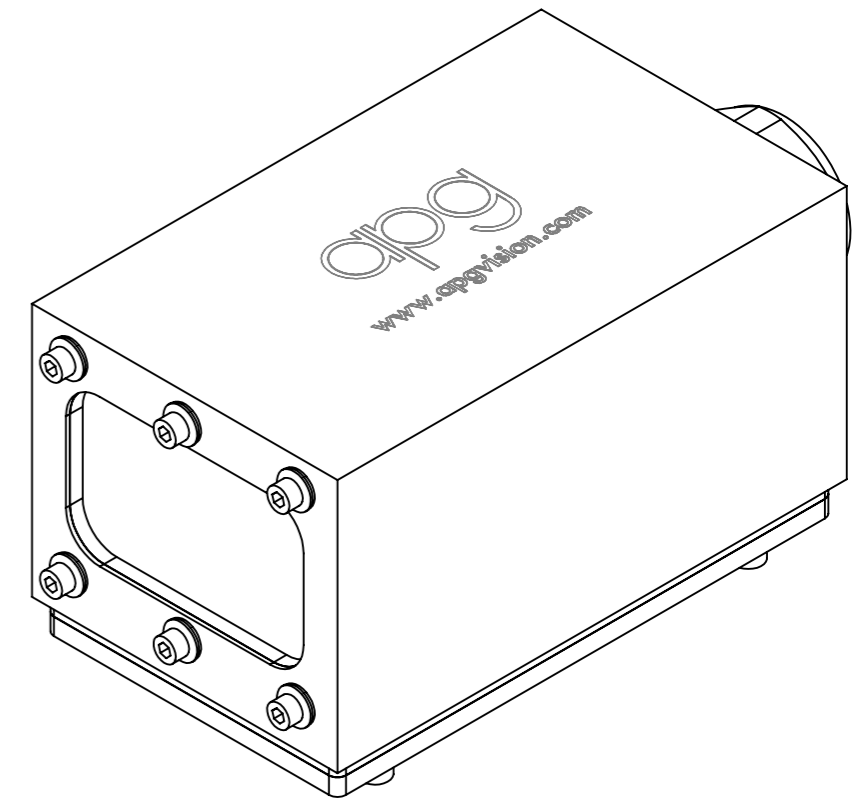
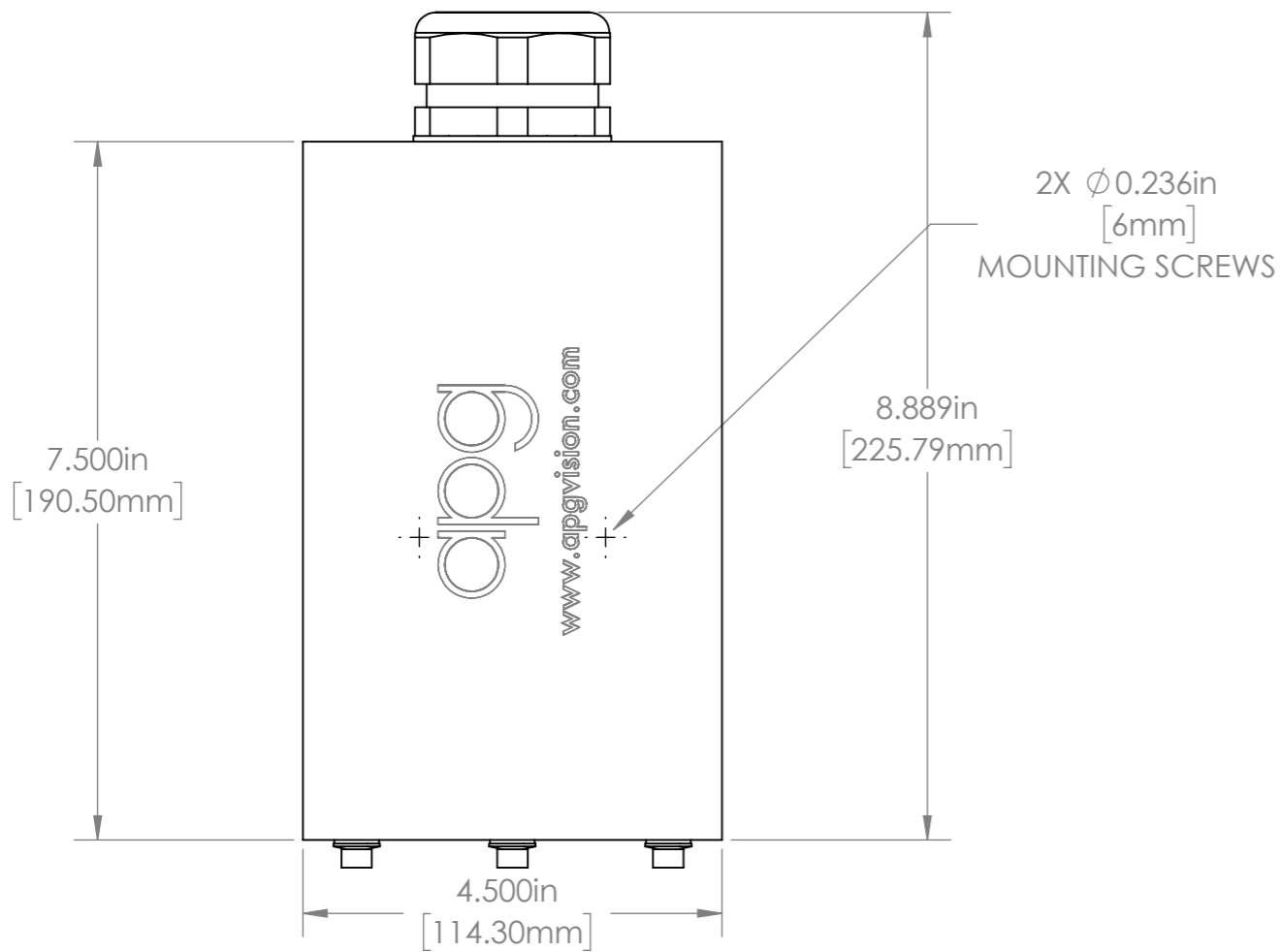

For more information please contact:



BOCK OPTRONICS INC.
 14 Steinway Blvd., Unit 7
 Toronto, Ontario M9W 6M6
 Tel: (416) 674-2804
sales@bockoptronics.ca
www.bockoptronics.ca

				UNLESS OTHERWISE SPECIFIED: DIMENSIONS ARE IN INCHES SURFACE FINISH: TOLERANCES: .000= +/- 0.005" .00= +/- 0.010"		FINISH: BURNISHED		Allison Park Group, Inc. (APG) 4055 Alpha Drive Allison Park, PA 15101 USA		DO NOT SCALE DRAWING		REVISION	
				LINEAR:		DEBUR AND BREAK SHARP EDGES		Phone +1 (412) 487-8211 Fax +1 (412) 486-3157		This document is the property of APG and is considered company confidential. The information in this document is the property of APG and may not be used, reproduced, or distributed in whole or in part without the prior written permission of APG.		TITLE: 42D-AA (DM500)	
				DRAWN SCHUBERT		SIGNATURE		DATE 8/7/2019					
				CHK'D				www.apgvision.com		DWG NO. 42D-AA ASSY DIMS		A3	
				APPVD				MATERIAL: 304 STAINLESS STEEL BODY 6061 T6 ALUMINUM BASE					
				MFG				WEIGHT:		SCALE: 1:5		SHEET 1 OF 1	
				Q.A				NOTES:					
				NO. CHANGE		DATE		INIT.					