

FORGE 5GigE

Industrial Machine Vision Cameras | FG-P5G-244S8M-C and FG-P5G-244S8C-C

KEY FEATURES

Building Reliable and Powerful Systems, Faster

Constructed on an all-new platform, the Forge camera is designed to offer the richest combination of on-camera pre-processing features, leverage the industry's most advanced sensors, and support the Trigger-to-Image Reliability (T2IR) framework for you to easily build robust systems.

Beyond 5GigE Performance

In addition to supporting link speeds of 1, 2.5, and 5GigE, the Forge offers burst mode to capture images into memory at speeds up to 10 Gb/s. This combined with a 500 MB image buffer allows engineers to control data transfer without overwhelming the host.

Ease of Integration

Forge is designed to simplify OEM integration with features including PoE, strong thermal management, and isolated triggering for streamlined peripherals and easier camera control.

Forge supports both Teledyne Spinnaker and Sapura SDKs and GigE Vision compliant software packages.

APPLICATIONS

- Electronics Inspection
- Food Processing
- Pharmaceuticals
- Sports Analytics
- Virtual Reality Motion Capture

High Speed, High Precision Image Acquisition

Forge is based on an all-new camera platform designed to support a feature and sensor set to easily built robust and powerful systems faster. It offers flexibility link speeds as well as the ability to go beyond 5GigE performance and control data transfer to the host. With OEMs in mind, Forge provides features for easy integration, a seamless upgrade path from 1GigE systems, and supports a choice of SDK's and GigE Vision compliant software packages.

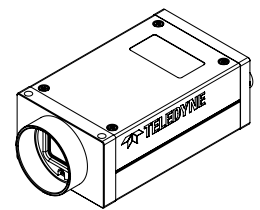
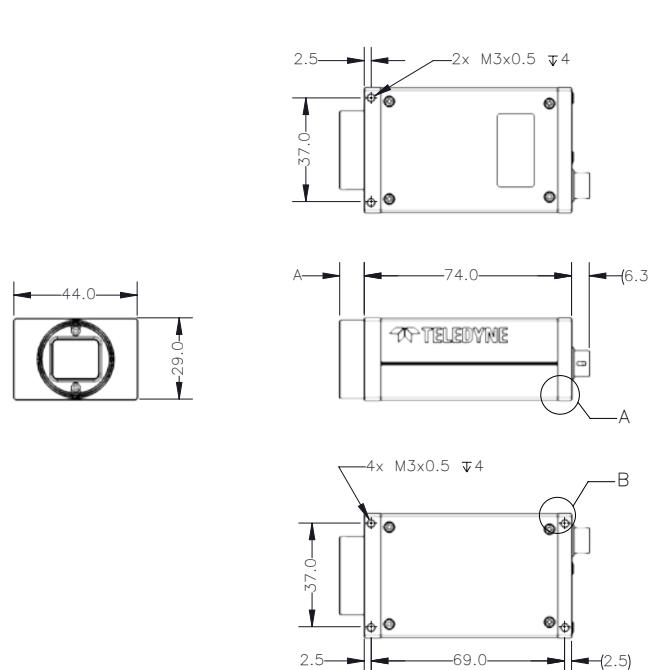

Unless otherwise stated,
 all dimensions in mm.
 Machine finish 1.6 µm

SPECIFICATIONS

	FG-P5G-244S8M-C	FG-P5G-244S8C-C
Resolution	5320 x 4600	
Frame Rate	25 fps standard 5GigE / 35 fps Burst Mode	
Megapixels	24.5 MP	
Chroma	Mono	Color
Sensor	Sony IMX540, CMOS, 1.2"	
Readout Method	Global shutter	
Pixel Size	2.74 μ m	
Lens Mount	C-mount	
ADC	8-bit / 10-bit / 12-bit	
Minimum Frame Rate	1 fps	
Gain Range	0 to 48 dB	
Exposure Range*	10 μ s to 30 s	
Acquisition Modes	Continuous, Single Frame, Multi Frame	
Partial Image Modes	Pixel binning, decimation, ROI	
Image Processing	Gamma, lookup table, and sharpness	Gamma, lookup table, saturation and sharpness
Sequencer	Up to 8 sets using 2 features	
Image Buffer	500 MB	
User Sets	2 user configuration sets for custom camera settings	
Flash Memory	4 MB non-volatile memory	
Opto-isolated I/O	1 input, 1 output	
Non-isolated I/O	1 bi-directional, 1 output	
Auxiliary Output	3.3 V, 120 mA maximum	
Synchronization	IEEE 1588 PTP	
Interface	5GigE PoE	
Power Requirements	Power over Ethernet (PoE), or 12 V nominal (9.5-24 V) via GPIO	
Power Consumption	8.5 W maximum PoE / 6.6 W maximum GPIO	
Dimensions/Mass	29 mm x 44 mm x 74 mm / 132 g	
Machine Vision Standard	GigE Vision v2.0	
Compliance	CE, FCC, KCC, RoHS, REACH / The ECCN for this product is EAR099	
Temperature	Operating: 0°C to 50°C (measured at the front face of the camera) / Storage: -30°C to 60°C	
Humidity	Operating: 20% to 80% (no condensation) / Storage: 30% to 95% (no condensation)	
Warranty	3 years	

*Values are the same in binning and no binning modes.



For more information please contact:

BOCK OPTRONICS INC.
 14 Steinway Blvd., Unit 7
 Toronto, Ontario M9W 6M6

Tel: (416) 674-2804
sales@bockoptronics.ca
www.bockoptronics.ca

This document does not contain information whose export/transfer/disclosure is restricted by the Canadian Export Control regulation. Teledyne FLIR reserves the right to make changes at any time without notice.
 © 2023 Teledyne FLIR

Revision Date: 2023 10 24